



ARCHITECTURAL REVIEW BOARD
REGULAR MEETING
~ AGENDA ~

Emily Kyriazi, Town Planner
<http://www.townofhaymarket.org/>

15000 Washington Street, Suite 100
Haymarket, VA 20169

Wednesday, July 26, 2023

7:00 PM

Council Chambers

I. Call to Order

II. Pledge of Allegiance

III. New Architectural Review Board Members Oath of Office

IV. Welcoming of New Board Members - Mayor Ken Luersen

V. Appointment of the Chairman and Vice Chairman

VI. Citizens Time

VII. Minute Approval

1. Architectural Review Board - Special Meeting - May 17, 2023 6:30 PM
2. Architectural Review Board - Regular Meeting - May 17, 2023 7:00 PM
3. Architectural Review Board - Regular Meeting - Jun 14, 2023 7:00 PM

VIII. Agenda Items

1. ZP #2023-0622 Sign Permit: Mountain Spring Podiatry 15100 Washington St
2. ZP #2023-0601: Exterior Elevations - Lifetime Smiles 15180 Washington Street
3. ARB Guidelines Work Session

IX. Old Business

X. New Business

XI. Planning Commission Updates

XII. Town Council Updates

XIII. Adjournment



ARCHITECTURAL REVIEW BOARD

SPECIAL MEETING ~ MINUTES ~

Emily Kyriazi, Town Planner
<http://www.townofhaymarket.org/>

15000 Washington Street, Suite 100
Haymarket, VA 20169

Wednesday, May 17, 2023

6:30 PM

Council Chambers

A Special Meeting of the Architectural Review Board of the Town of Haymarket, VA, was held this evening in the Council Chambers, commencing at 6:30 PM.

Chairperson Marchant Schneider called the meeting to order.

I. Call To Order

Chairperson Marchant Schneider: Present, Board Member Suzanne Luersen: Present, Commissioner Robert Hallet: Absent, Board Member Stacy Curran: Present, Vice Chairman Benjamin Barben: Present.

II. Site Visit - 6712 Jefferson Street

Chairman Schneider stated that the purpose for the special meeting was to do a site visit on the demolition permit application for 6712 Jefferson Street. The Architectural Review Board recessed the meeting to conduct the site visit.

III. Close Special Meeting

After returning from the site visit, Chairman Schneider asked for a motion to adjourn the Special Meeting.

Board Member Luersen moved to adjourn the Special Meeting with a second by Vice Chairman Barben. The motion carried and the meeting was adjourned at 6:58 p.m.

1. Motion to Adjourn

RESULT:	ADOPTED [UNANIMOUS]
MOVER:	Suzanne Luersen, Board Member
SECONDER:	Benjamin Barben, Vice Chairman
AYES:	Marchant Schneider, Suzanne Luersen, Stacy Curran, Benjamin Barben
ABSENT:	Robert Hallet

Submitted:

Approved:

Kimberly Henry, Clerk of the Council

Marchant Schneider, Chairman

Minutes Acceptance: Minutes of May 17, 2023 6:30 PM (Minute Approval)



ARCHITECTURAL REVIEW BOARD

REGULAR MEETING ~ MINUTES ~

Emily Kyriazi, Town Planner
<http://www.townofhaymarket.org/>

15000 Washington Street, Suite 100
Haymarket, VA 20169

Wednesday, May 17, 2023

7:00 PM

Council Chambers

A Regular Meeting of the Architectural Review Board of the Town of Haymarket, VA, was held this evening in the Council Chambers, commencing at 7:00 PM.

Chairperson Marchant Schneider called the meeting to order.

I. Call To Order

Chairperson Marchant Schneider: Present, Board Member Suzanne Luersen: Present, Commissioner Robert Hallet: Absent, Board Member Stacy Curran: Present, Vice Chairman Benjamin Barben: Present.

II. Pledge of Allegiance

Chairman Schneider invited everyone to stand for the Pledge of Allegiance.

III. Citizens Time

There were no citizens present at this meeting wishing to address the Architectural Review Board.

IV. Minute Approval

1. Architectural Review Board - Regular Meeting - Apr 19, 2023 7:00 PM

Vice Chairman Barben moved to approve the minutes from April 19, 2023. Board Member Luersen seconded the motion. The motion carried.

RESULT:	ACCEPTED [UNANIMOUS]
MOVER:	Benjamin Barben, Vice Chairman
SECONDER:	Suzanne Luersen, Board Member
AYES:	Marchant Schneider, Suzanne Luersen, Stacy Curran, Benjamin Barben
ABSENT:	Robert Hallet

V. Agenda Items

1. Demolition Permit Request - 6712 Jefferson Street

Chairman Schneider shared that this was a continuation from the April 19, 2023 meeting. He continued to share that the Architectural Review Board conducted a site visit of the property at their special meeting prior to this evening's regular monthly meeting. Town Manager Emily Kyriazi began the discussion of this application by stating that the minutes from a previous meeting that the Board requested has been supplied for review in this evening's agenda. She stated that the site visit was completed early that evening as this has been the standard that the ARB has set for demolition applications. Mrs. Kyriazi opened the floor for discussion or to ask the applicant or staff any questions about the application or the property. Chairman Schneider asked the applicant for any follow up. Michelle Rosati, the attorney for the applicant, thanked the Architectural Review Board for their time and for doing the site visit. She stated that she would like to refer back to the written submission and would like to mention one thing for the record. She stated that there is a pretty significant addition to the original house in the rear that is visible from the public way that was built in the 1970's. Ms. Rosati stated that at this time she would answer any questions from the ARB. The ARB did not have any questions for Ms. Rosati. Chairman Schneider provided a brief history regarding the property and house. He stated that the last time this property came before the Architectural Review Board, there was an interested party wanting to purchase the property. He stated that at that time the applicant didn't feel that there was a need for any additional assessments or inspections needed since the interested party was going to rehab the structure. Mr. Schneider stated that since there was an interest, a different criteria of policies, ordinances and guidelines for adaptive reuse and preservation of a Town historic structure was being considered. With those guidelines in place, the ARB denied

Minutes Acceptance: Minutes of May 17, 2023 7:00 PM (Minute Approval)

the application on those basis and was later upheld by the Town Council. At that point, that interested party rescinded his application and another interested party was looking at the property. With the new interested party looking at the property, the Town Council looked at rezoning the property so that it would make some viable options for the property. However, that did not move forward. He stated there had been several attempts to get an interested party into the structure which is the key differences of between now before. Chairman Schneider continued to state that an inspection report was submitted this time and that Ms. Rosati did a good job with addressing the criteria in the Town's zoning ordinance and the ARB design guidelines. He stated that given the circumstances that it would be appropriate to allow the structure to come down.

Chairman Schneider moved that the Architectural Review Board approve COA ZP# 2023-0422 to demolish the Baker/Bean Structure at 6712 Jefferson Street, subject to the following Conditions of Approval, Findings for Approval, and Applicant Acknowledgement: CONDITIONS OF APPROVAL - 1. Photo Documentation. Prior to issuance of a Town Zoning Permit for demolition of the structure, the Applicant will provide the Town complete photographic documentation of the exterior and interior of the structure. Photo documentation to include all four elevations of the exterior of the structure, including views from Jefferson Street that demonstrate the structure's relationship to adjacent structures and the streetscape. Photo documentation shall also include architectural details of the structure, such as building eaves, columns, entry doors, windows, etc. Interior photos should note room layout and similar architectural details. Photographic documentation to be submitted to the Town in hard copy and digital formats. 2. Written Description. Prior to issuance of a Town Zoning Permit for demolition of the structure, Applicant will provide to the Town a complete written description of the exterior and interior of the structure. Written documentation to include interior and exterior dimensions of the structure, orientation of the building on the property through a plat or similar description, and a description of the architectural style, period and method of construction of the structure. Written descriptions to be submitted to the Town in hard copy and digital formats. FINDINGS FOR APPROVAL - 1. Conditional approval of the demolition requires photographic and written documentation of the architectural elements of the structure and its context relative to the Town's streetscape and adjacent properties for future study and architectural reference. 2. Demolition of the structure has the potential to improve, and/or continue the viability of, occupied historic structures (Old Bank Building, Masonic Lodge) that are proximate the subject structure. APPLICANT ACKNOWLEDGEMENT - 1. In accepting the ARB decision, the Applicant and/or Property Owner acknowledges the above requirements and that the requisite Photo Documentation and Written Description may be requested and to be submitted and accepted by the Town prior to any Town Zoning Permit / Town Zoning Verification Letter, or other Town permission necessary authorizing said demolition. **Board Member Curran seconded the motion. The motion carried by a roll call vote.**

RESULT:	ADOPTED [UNANIMOUS]
MOVER:	Marchant Schneider, Chairperson
SECONDER:	Stacy Curran, Board Member
AYES:	Marchant Schneider, Suzanne Luersen, Stacy Curran, Benjamin Barben
ABSENT:	Robert Hallet

2. ZP #2023-0414 Sign Permit Application: Self Storage Plus - 6600 James Madison Hwy
Town Planner Thomas Britt shared that the Haymarket Self Storage facility located at 6600 James Madison Hwy sold their business to Self Storage Plus. He continued to state that the application before the Board is a sign permit application from Self Storage Plus. Mr. Britt invited the representatives from Absolute Signs, the sign company representing Self Storage Plus, to the podium for further discussion of the application and design. The representatives stated that the application consists of two site entrance signs and one aluminum sign for the building. They continued to state that the signs comply with the sign guidelines established by the Town. The representative stated that the placement of the signs were in question. There was a question from the ARB regarding the materials. They shared that there would be a building sign would be of aluminum panel of digital print which would be screwed into the side of the building and

Minutes Acceptance: Minutes of May 17, 2023 7:00 PM (Minute Approval)

another aluminum sign attached to the building. The representative shared that for the site sign, the new sign would replace the existing Haymarket Storage sign with a 4x4 pressure treated post with an MDO which would be painted. He continued to share that the site sign that has the arrow would basically have the same set up. The representative shared that there would be no lighting. The representatives stated that their intention was to replace and mimic what was existing. The Board asked Town Planner Britt if the wall signs were within the Town's ordinance. Mr. Britt confirmed that they were. There was a question if the company received written permission from the property owner for the off site signs. Town Manager Emily Kyriazi explained to the applicant that one of the signs presented is within the VDOT right of way. Mrs. Kyriazi stated that she could provide a point of contact for the applicant. Mrs. Kyriazi shared that the Haymarket Self Storage sign was grandfathered in is on the Aldi property and that the applicant would need written acknowledgement from the property owner. The ARB also stated that they would want the off site sign be of the same height at 6 1/2 feet of the one that was being replaced. There was a discussion on changing the support posts color to something more muted and finishing the post with a finial. They also discussed the lettering. Chairman Schneider recommended that this item be deferred until the next Architectural Review Board meeting so that the applicant can make the appropriate changes to the Washington Street sign to be of similar height sign it is replacing, consider different color schemes for the posts with a matching border and install a decorative top, and secure the property owners consent for the two off site signs.

Chairman Schneider moved the ARB defer action on ZP #2023-0414- sign permit application for Self Storage Plus,6600 James Madison Hwy to the June 21st Architectural Review Board meeting. Board Member Curran seconded the motion. The motion carried.

RESULT:	ADOPTED [UNANIMOUS]
MOVER:	Marchant Schneider, Chairperson
SECONDER:	Stacy Curran, Board Member
AYES:	Marchant Schneider, Suzanne Luersen, Stacy Curran, Benjamin Barben
ABSENT:	Robert Hallet

3. Kiddie Academy Revised Elevation

Town Planner Thomas Britt shared that at the April meeting, the ARB discussed the exterior elevations for Kiddie Academy. He shared that the Board discussed adding color renderings so that they could see the palette used. He shared that the applicant has returned with the requested color renderings with an updated design. There was a discussion on going with another prototype of a Kiddie Academy. The applicant stated that every community is different and that each community wants something different on the building that matches their community. He stated that if he brought in something from another community, it would not match the same concept as what the Town is looking for. The applicant stated that each of his designs are unique. The applicant provided the materials that would be used. The applicant showed the renderings of the building including front, rear and side elevations. A discussion followed on the building design. The Board thanked the applicant for taking the suggestions from the last meeting and incorporating it into the design. There was a discussion on the front elevation and flattening the roof line. The applicant asked if the Board could approve the design with that condition of modifying the rendering and he will send the revisions and if not adequate, he could make the necessary changes. There was also a discussion on the windows in the front and side of the building. They also discussed the placement of the fence that is relative to the building. The color and type of fence was also discussed. The applicant stated that the fence was black in color and would be either of aluminum or steel material, a picket that is three inches on center. He also stated that the fence would be 4 foot high at the sides and 5 foot high at the playground. Town Manager Emily Kyriazi asked that the applicant submit those specifications to the Town Planner. Mrs. Kyriazi also inquired about the parking at the front of the building and the need for bollards to be installed. Town Planner Thomas Britt asked for diagram and color schemes for the trash enclosures. The applicant shared that they would use the exact same material that is on the building. The ARB also discussed the color of the playground by requesting an warm earth tone color. There was a discussion on the lighting.

Minutes Acceptance: Minutes of May 17, 2023 7:00 PM (Minute Approval)

With no further discussion, Chairman Schneider moved that the Architectural Review Board approve ZP #2023-0415 Kiddie Academy revised elevations subject to the following conditions: 1. The trash enclosure will be of a design and materials similar to the main structure; 2. fencing will be either steel or aluminum painted black; 3. bollards painted black; 4. playground of earth tone colors; 5. the front and rear elevations provided at the meeting will be revised to provide a flattened gable with a height no higher than the highest point on the proposed structure. All these revisions are to be submitted to the Zoning Administrator prior to the issuance of the zoning permit and the Zoning Administrator will affirm that these changes are reflected in the revised elevation and application materials. Board Member Curran seconded the motion. The motion carried unanimously.

4. ZP #2023-0349 Sign Permit Resubmission: Taco Bell - 6635 Watts Road

Town Planner Thomas Britt handed the floor over to Zoning Administrator Emily Kyriazi to describe the previous submission from of the sign permit from Taco Bell prior to discussing the re-submission. Mrs. Kyriazi stated that she wanted to talk to the Board about the previous approval of Taco Bell and how it relates to the Crossroads Village project that staff has been working on since 2019. She stated that she wanted to review what was done in the past, the reasoning why and why another restaurant was designed off the Taco Bell approval and how that currently exists today so that the Board would have the information for what's being asked for in this revision presented before them at this evening's meeting. She shared that in October 2019, the Architectural Review Board looked at the Taco Bell architectural plans to include the sign plans. She continued to state that at time, the ARB approved a full sign plan package. She stated that since then there have been some modifications and also a zoning text amendment that addresses signs. She stated that at that time, the Architectural Review Board denied any mural going up on the wall and modified the signage on the front and side of the building. She also stated that there were to be no letters on the tower of the architectural plans, no internally illuminated signs, and the bollards in the parking lot were to be bronze in keeping with the building. Since then, the ARB reviewed the Popeye's design plan and shared that the June 16, 2021 minutes reflect that the discussion circulated around the neighboring property, the Taco Bell property and what was approved in relation to their sign and their building colors. Mrs. Kyriazi shared that the ARB at that time was trying to keep with the color schemes, the design and the feel with the Crossroads Village as an entire project. They did not approve any internally lit signs for Popeye's but permitted them to put up the goose neck lighting. She stated that she can make the minutes available but wanted to give some history on the neighboring restaurants being Taco Bell and Popeye's and what was approved. She turned the floor back over to Town Planner Thomas Britt to consider the re-submission of the Taco Bell signage application.

Mr. Britt stated that the new application involves signage dimensions, design and placement as well as other exterior items on the site. He invited the applicant to the podium for further discussion. Ms. Jerrie Howell, Capital Signs, shared that she would take any comments from this evening's meeting on the sign's back to Taco Bell. She stated that what it is being proposed is a site plan with a sign schedule with an elevation drawing. She continued to state that on the elevation drawing, a bell logo sign is being proposed on the front elevation and the left side elevation would be an additional bell logo sign with a Taco Bell letter set. She provided the materials and colors listed on the details of the bell logo along with the letter set. In addition she shared that there would be an order point canopy with a dual outdoor menu board and a 9 foot clearance bar. Directional signs were provided. At this point she answered questions from the ARB. A question was asked about the key changes since the original application. Ms. Howell stated that her company was not part of the 2019 process but thought from the remarks that in 2019, Taco Bell was still in the architectural stage of the project and had not yet hired an installer. Mrs. Kyriazi stated that she brought forth the information from 2019 so that the ARB could make the best decision based on what was approved for that development from the master sign plan that was approved for the businesses in Crossroads Village that face Washington Street. Questions were asked about the menu board, the placement of the bell and the Taco Bell sign, and the lighting. There was also a discussion on the order point canopy height. A discussion followed on the directional signs to match Popeye's.

Chairman Schneider moved that the Architectural Review Board approve ZP #2023-0349: sign permit re-submission for Taco Bell at 6635 Watts Road based on the following

conditions: 1. the application signage sheet will be revised to match the approvals by the ARB and match the rest of the sign package; 2. the wall signage will be revised to state no internal illumination; 3. directional signage sheets will be revised to state that the height will match the Popeye's next door with no internal illumination. These changes will be made to the plan set which will be submitted to the Zoning Administrator for approval and it is the discretion of the Zoning Administrator to issue the permit once these conditions are met. Board Member Curran seconded the motion. The motion carried unanimously.

VI. Old Business

Town Planner Thomas Britt provided the Old Business updates for this evening's meeting. He stated that the staff signed a third revision of the site plan for the Crossroads Village Center dealing with utilities and emergency parking lane for the Pulte town homes. Mr. Britt shared that the town homes will be moving quickly. He also shared that staff is working on signing the Town Center site plan and starting the bidding process. In addition, he shared that the staff is looking at the second submission of the final site plan for Kiddie Academy. He provided information on a new dental office and that the site plans for the building is under review as well as the site plan for town homes at Bleight Drive. He stated that these plans are before the Planning Commission.

VII. New Business

Town Manager Emily Kyriazi shared information on the new businesses that are scheduled to open in July. She also shared that the Town also has some new tenants occupying the second floor of the Town Hall building. There was a question on the update of the Town sidewalk. Mr. Britt shared that the Town is at the 90% completion on the design phase.

VIII. Planning Commission Update

Town Planner Britt shared that the Planning Commission has been working on Comp Plan amendments mostly DEQ related.

IX. Town Council Update

Chairman Schneider shared that he is working with Vice Mayor Pater on a questionnaire addressing the future of the Town Park building. He stated that the questionnaire will ask for input as to whether the building should be renovated, the building should be torn down and a replica built, or if the building should be torn down and a pavilion be erected. Mr. Schneider also shared that the Council is preparing to pass the FY24 budget by holding a public hearing on May 30th with a reduced tax rate of .0111 cents per \$100 of assessed value.

Mr. Schneider shared that there is a community meeting this evening at the Haymarket Hilton Garden Inn in regards to a property that might abut to and occupy part of the Town Conservation district for an affordable housing.

Mr. Schneider asked about the vacancy on the Planning Commission. Town Clerk Henry stated that there is still a vacancy on the Planning Commission. She also shared that she recently received a letters from both Board Member Curran and Board Member Luersen that they wish not to serve another term on the Architectural Review Board. Ms. Henry shared that their terms will expire June 30, 2023 and that staff will start advertising those vacancies as well.

X. Adjournment

With no further business before the Architectural Review Board, Vice Chairman Barben moved to adjourn with a second by Board Member Luersen. The motion carried.

1. Motion to Adjourn

RESULT:	ADOPTED [UNANIMOUS]
MOVER:	Benjamin Barben, Vice Chairman
SECONDER:	Suzanne Luersen, Board Member
AYES:	Marchant Schneider, Suzanne Luersen, Stacy Curran, Benjamin Barben
ABSENT:	Robert Hallet

Minutes Acceptance: Minutes of May 17, 2023 7:00 PM (Minute Approval)

Submitted:

Approved:

Kimberly Henry, Clerk of the Council

Marchant Schneider, Chairman

Minutes Acceptance: Minutes of May 17, 2023 7:00 PM (Minute Approval)



ARCHITECTURAL REVIEW BOARD

REGULAR MEETING ~ MINUTES ~

Emily Kyriazi, Town Planner
<http://www.townofhaymarket.org/>

15000 Washington Street, Suite 100
Haymarket, VA 20169

Wednesday, June 14, 2023

7:00 PM

Council Chambers

A Regular Meeting of the Architectural Review Board of the Town of Haymarket, VA, was held this evening in the Council Chambers, commencing at 7:00 PM.

Vice Chairman Benjamin Barben called the meeting to order.

I. Call to Order

Chairperson Marchant Schneider: Remote (7:15 PM), Board Member Suzanne Luersen: Present, Commissioner Robert Hallet: Absent, Board Member Stacy Curran: Present, Vice Chairman Benjamin Barben: Present.

II. Pledge of Allegiance

Vice Chairman Ben Barben invited everyone to stand for the Pledge of Allegiance.

III. Citizens Time

At this time, Mayor Ken Luersen approached the podium to recognize and thank Board Member Stacy Curran and Board Member Suzi Luersen for their service to the ARB and to the Town during their terms in office. He shared that both Mrs. Curran and Mrs. Luersen's terms end on June 30, 2023 and that this was their last meeting on the Board. Mayor Luersen wished both Board Members well for the future and stated his gratitude for their service.

IV. Minute Approval

Town Clerk Kim Henry shared that the minutes from the May meeting have not been completed for approval at this meeting but will have them finished for their July meeting.

V. Agenda Items

1. 6600 James Madison Highway Sign Application

Vice Chairman Barben asked Town Planner Thomas Britt for any updates to the application prior the Board taking action. Mr. Britt shared that the application was brought before the Board at the May meeting. Mr. Britt shared that at the May meeting the Board discussed the height of the sign, especially the free standing sign at Washington Street, the color of the sign and the posts. Mr. Britt shared that the applicant updated changes to the sign that was discussed at the May meeting. Mr. Britt invited the representative from Absolute Signs, the applicant, to the podium for any additional questions or discussion from the ARB. The Board asked Mr. Britt about the revisions that were discussed at the May Architectural Review Board meeting. Mr. Britt stated that the property owner supplied an easement agreement for the location of the free standing signs. He shared that both easements were good from the Town Planner perspective. Mr. Britt also shared the packet page number for the updated colors for the posts. He also shared that there was an adjustment to the height of the sign.

Board Member Curran moved that the Board approve COA for ZP #2023-0414, as presented, for the Self Storage Plus Signage on 6600 James Madison Highway with the preference on color should be black. Board Member Luersen seconded the motion. The motion carried by a roll call vote.

Minutes Acceptance: Minutes of Jun 14, 2023 7:00 PM (Minute Approval)

RESULT:	ADOPTED [UNANIMOUS]
MOVER:	Stacy Curran, Board Member
SECONDER:	Suzanne Luersen, Board Member
AYES:	Suzanne Luersen, Stacy Curran, Benjamin Barben
ABSENT:	Marchant Schneider, Robert Hallet

2. VCA Healthy Paws Fence Replacement

Town Planner Thomas Britt shared that the application before the Board was an updated document and fence application for Healthy Paws located at 14840 Washington Street. He stated that one of the issues with the old fence is that it's leaning and deteriorating. He provided the ARB with the new materials being used in the evening's agenda packet. He invited the applicant to the podium to answer any questions from the Architectural Review Board. Sharyl Mayhew, manager of VCA Healthy Paws, shared that the existing fence is at least 24 years old and that it is sagging and falling down. She stated that they are not changing the foot print of the fencing only replacing board for board with a quality new vinyl type material. She stated that it will be similar to the other fences neighboring the property so it will look more in line to be esthetically pleasing. A short discussion followed.

Board Member Curran moved that the Board approve the COA for ZP #2023-0619, as presented, for the VCA Healthy Paws fence at 14840 Washington Street. Board Luersen seconded the motion. The motion carried by a roll call vote.

RESULT:	ADOPTED [UNANIMOUS]
MOVER:	Stacy Curran, Board Member
SECONDER:	Suzanne Luersen, Board Member
AYES:	Suzanne Luersen, Stacy Curran, Benjamin Barben
ABSENT:	Marchant Schneider, Robert Hallet

3. Lifetime Smiles Exterior Elevations

Town Planner Thomas Britt shared that the staff is currently reviewing the site plan for a new dental office located on the Quarles property pad site behind the CVS and Virginia National Bank buildings. He stated that the applicant provided the Board with digital copies of the color schemes for the elevations as well as material samples and contextual pictures of the neighboring properties. Mr. Britt invited the architect and owners of Lifetime Smiles Dental to the podium to answer any questions from the Architectural Review Board. The architect stated that they looked at the 3 surrounding buildings for guidance on the color scheme and would like to a brick front of the building that would wrap slightly around the sides. She stated that there will be a brick water table on all 4 sides and will have a hardieplank siding for the rest of the building. She continued to state that it will have a efface cornice tapered inflation roof with down spouts out the back. She shared that there has been one change in the drawing in that the rear doors will move to the side because of a drainage issue. There was a question about the mortar color. The architect stated that the mortar color would likely be tan in color. Vice Chairman Barben thanked the applicant for blending with what's already there. However he asked about the eaves portion at the front of building that it 6-7 feet above the rest of the building. The architect stated that it was to hide mechanical systems that exist on the roof. There was a brief question on the exterior lighting around the building. The architect shared that they have not selected that yet at this time. The applicant also shared that they are trying to keep all the units on the roof. She stated that there would not be any condensers on pads and that she believes that there is a trash enclosure on the site that they can use but the site plan does not have a rendering of the trash pad enclosure. She stated that there would not be any outdoor seating or need for fencing.

At this time, Town Clerk Kim Henry informed the Board that Chairman Marchant Schneider is joining the meeting remotely. Vice Chairman Barben brought Mr. Schneider up to date on what was discussed thus far. Mr Schneider recommended that the building have a minimum of 3 sides of the same architecture but to be consistent with the buildings around them, he preferred to see all 4 sides be the same. The applicant stated that they tried to dress up the 2 sides with some ribbon windows. She stated that what's driving some of the exterior architecture is the interior layout. She stated that they are dental offices suites that are trying to capture the

Minutes Acceptance: Minutes of Jun 14, 2023 7:00 PM (Minute Approval)

windows but would like to keep them up high for privacy of the patient in the dental chair. She also stated that going from brick to siding will help emphasize where the front of the building is as not to confuse the patient since there will be parking on all sides of the building. A discussion continued on exterior materials. There was also a discussion on where the building would sit in relation to the new Kiddie Academy building. Mr. Britt stated that it would sit in front of Kiddie Academy. The architect stated that there would be a landscaping barrier between the dental office building and Kiddie Academy. There was a discussion on the dental office becoming "the bridge" between the old buildings to the new development. Vice Chairman Barben suggested that the applicant come before the ARB at the July meeting providing a three sided brick option for them to review and decide on. There was also a suggestion that the applicant provide the lighting options as well for review at the July meeting.

Vice Chairman Barben deferred this item until the next meeting with the applicant resubmitting the elevations presented herein as well as the modified options that has the left and right elevations where hardieboard is shown be replaced with brick. There was a clarification on the parapet from the original design fitting into the 3 sided brick elevation. No further action was taken.

VI. Old Business

Town Planner Thomas Britt gave the Old Business update. He shared that Kiddie Academy has resubmitted their exterior architecture elements and that is in review. He stated that Taco Bell has also submitted their revisions on the architectural elements and is waiting on administrative approval of the requested changes from the Board. He also stated that the site plan for Lifetime Smiles is under preliminary review and the Kiddie Academy site plan will be before the Planning Commission at their next meeting. He continued to state that Popeye's is complete and waiting for their occupancy permit. Lastly he stated that the Pulte town homes in Crossroads Village is well under construction.

VII. New Business

Town Planner Thomas Britt asked if the ARB July meeting could be rescheduled to Wednesday, July 26th. There was a short discussion on the topic. There was a consensus of the Architectural Review Board to move the meeting from Wednesday, July 19th to Wednesday, July 26th.

Mr. Britt shared that at a previous meeting, there was a discussion about the historic district and the historic overlay map. He stated that he will be bringing before the ARB at their next meeting the historic district guidelines along with the historic district map for ARB consideration to discuss and amend as needed.

There was a question about the new home construction on Bleight Drive. Mr. Britt stated that the was still working the outside agency comments on the site plan review. He stated that the elevations should be coming to the ARB within the next few months.

There was also a short discussion regarding the signs for the Town Hall building. Mr. Britt shared that the Town Manager is working on that with the Town Treasurer.

VIII. Planning Commission Update

Town Planner Thomas Britt gave the Planning Commission updates for this evening's meeting. He shared that the Commission has been working on the appendix of the Comprehensive Plan and updating any maps and updating guidelines that were given by DEQ on the Chesapeake Bay Preservation Act.

IX. Town Council Update

Chairman Schneider gave the Town Council updates. He shared that the Town Council adopted a new and lower real estate tax rate at their June 5th meeting. He also shared that Fox5, a Washington DC tv channel, would be broadcasting their morning news from the Town on Friday, June 16th from 6 am - 11 am. He stated that Washington Street in front of Town Hall would be closed during this time and encouraged everyone to come out for a fun morning. Lastly, he shared that the Town Council will be sending out a survey to get public input on the future of the Town Park and Town Park Building. He stated that the Town Council is looking at several options such as a park services building, replacing the building with a pavilion or rehab the building as a meeting space.

X. Adjournment

With no further business before the Architectural Review Board, Board Member Suzi Luersen moved to adjourn with a second by Board Member Stacy Curran. The motion carried.

1. Motion to Adjourn

RESULT:	ADOPTED [UNANIMOUS]
MOVER:	Suzanne Luersen, Board Member
SECONDER:	Stacy Curran, Board Member
AYES:	Marchant Schneider, Suzanne Luersen, Stacy Curran, Benjamin Barben
ABSENT:	Robert Hallet

Submitted:

Approved:

Kimberly Henry, Clerk of the Council

Marchant Schneider, Chairman

Minutes Acceptance: Minutes of Jun 14, 2023 7:00 PM (Minute Approval)



Town of Haymarket
15000 Washington Street, #100
Haymarket, VA 20169
703-753-2600

Thomas Britt
TOWN PLANNER

MEMORANDUM

TO: Architectural Review Board
FROM: Thomas Britt
DATE: July 19, 2023
SUBJECT: ZP #2023-0622 Mountain Spring Podiatry Sign Application

APPLICATION SUMMARY:

Business/ Applicant: Self Storage Plus

Street Address: 15100 Washington Street Suite #203

Proposed Use: New Sign for New Tenant

Applicant's Brief Description of the Activity: Addition of new tenant signage

Town Planner Assessment		
Zoning Ordinance	Application Details	Staff Response
Sec. 58-16.8 Matters to be considered by board in acting on appropriateness of erection, reconstruction, alteration, restoration or demolition of building or structure.	Addition of new signage for the new tenant, 17.5 sqft wall sign, placed 17ft high, with channel lettering and brand logo attached directly to building.	The proposed alteration is visible from the public right of way. The sign will require a height and dimensional adjustment to meet the zoning ordinance.
Sec. 58-16.8 (1) Exterior architectural features, including all signs, which are subject to public view from a public street, way or place.	Addition of new signage for the new tenant, 17.5 sqft wall sign, placed 17ft high, with channel lettering and brand logo attached directly to building.	The proposed alteration is visible from the public right of way. The material is aluminum, white lettering with logo next to business title.
Sec. 58-16.8 (2) General Design Arrangement	Addition of new signage for the new tenant, 17.5 sqft wall sign, placed 17ft high, with channel lettering and brand logo attached directly to building.	The design is in keeping with the guidelines. Signage will be attached to brick façade with screws.
Sec. 58-16.8 (3) Texture, material and color	Addition of new signage for the new tenant, 17.5 sqft wall sign, placed 17ft high, with	Addition of new signage for the new tenant, 17.5 sqft wall sign, placed 17ft

	channel lettering and brand logo attached directly to building.	high, with channel lettering and brand logo attached directly to building.
Sec. 58-16.8 (4) The relation of the factors, subsections (1), (2), and (3) of this section, to similar features of the buildings and structures in the immediate surroundings	Addition of new signage for the new tenant, 17.5 sqft wall sign, placed 17ft high, with channel lettering and brand logo attached directly to building.	The design is in keeping with the guidelines and the immediate surrounding tenants and buildings.
Sec. 58-16.8 (5) The extent to which the building or structure would be harmonious with or obviously incongruous with the old and historic aspect of the surroundings	Addition of new signage for the new tenant, 17.5 sqft wall sign, placed 17ft high, with channel lettering and brand logo attached directly to building.	The design is in keeping with the guidelines and the immediate surrounding tenants and buildings.
Sec. 58-16.8 (6) In the case of a building to be razed, a primary consideration will be the extent to which its continued existence would tend to protect irreplaceable historic places and preserve the general historic atmosphere of the Town	Not applicable	Not applicable
Sec. 58-16.8 (7) The extent to which the building or structure will promote the general welfare of the Town, and all citizens, by the preservation and protection of historic places and areas	Addition of new signage for the new tenant, 17.5 sqft wall sign, placed 17ft high, with channel lettering and brand logo attached directly to building.	This matter is at the discretion of the ARB
Sec. 58-16.8 (8) The extent to which the building or structure will promote the general welfare by: (a) Maintaining and increasing real estate values (b) Generating business (c) Creating new positions (d) Attracting tourists, students, writers, historians, artists and artisans, and new residents	Addition of new signage for the new tenant, 17.5 sqft wall sign, placed 17ft high, with channel lettering and brand logo attached directly to building.	These matters are at the discretion of the ARB

(e) Encouraging study of and interest in American history		
(f) Stimulating interest in and study of architecture and design		
(g) Educating citizens in American culture and heritage		
(h) Making the Town a more attractive and desirable place in which to live		
Comprehensive Plan		
Comp Plan 1.5.3 Historic Resource Inventory List	15100 Washington Street Suite #203	The main structure/site IS NOT listed as a Historic Resource
Comp Plan 1.5.4 Potential Archaeological Site	15100 Washington Street Suite #203	The site is not one of those listed as a potential archaeological site in the Comprehensive Plan
Architectural Review Board Historic Guidelines		
I. Introduction (E) Community Design and the Comprehensive Plan	15100 Washington Street Suite #203	B-1 Property
II. Streetscape and Site Design		
II. (a) Washington Street Enhancement Project	Not applicable	Not applicable
II. (b) Streetscapes Other Than Washington Street	Not applicable	Not applicable
II. (c) Fences and Walls		
II. (d) Lighting (Free Standing/Posts)	Not Applicable	Not Applicable
II. (e) Telecommunication Dishes, Drums and Towers	Not Applicable	Not Applicable
II. (f) Screening	Not Applicable	Not Applicable
III. New Construction and Additions to Existing Non-Historic and Non-Contributing Structures		
III. (a) General Guidelines	<i>"to create a more pleasing blend of historic and new elements in the Town, new structures shall be compatible with the prevailing and recognized historic architectural character of the existing adjacent structures"</i>	These matters are at the discretion of the ARB
III. (b) Colors		The colors for the signage proposed are outside of the Historic Color Palette, the colors proposed are consistent with the applicant's brand.
III. (c) Exterior Elements		Not Applicable

III. (d) Chimneys	Not Applicable	Not Applicable
III. (e) Roofing	Not Applicable	Not Applicable
III. (f) Lighting, (attached to structure)	None	None
III. (g) Windows and Doors	Not Applicable	Not Applicable
III. (h) Decks	Not Applicable	Not Applicable
III. (i) Handicapped Ramps	Not Applicable	Not Applicable
III. (j) Awnings	Not Applicable	Not Applicable
IV. Guidelines for Alterations or Additions to Historic Structures or Contributing Structures		
IV. (a) General Guidelines	Not Applicable	Not Applicable
V. Signage	Not Applicable	Not Applicable, not historic or contributing
VI. Demolition Guidelines	Not Applicable	Not Applicable
VII. Situations Not Covered, Additional Requirements	Not Applicable	Not Applicable

STAFF RECOMMENDATION:

Based on the above assessment of the proposed signage at 15100 Washington Street Suite #203, the Town Planner recommends approval of the addition.

Draft Motion: “I move the Board approve the COA for ZP#2023-0622, as presented, for the Mountain Spring Podiatry Sign on 15100 Washington Street Suite #203 with the following condition: all sign specific standards listed in the zoning ordinance are met.”

Or an alternate motion.

Attachment: 01 Sign App for Mountain Spring Podiatry, Staff Report (6239 : ZP #2023-0622: Sign Permit - Mountain Spring Podiatry 15100



ZONING PERMIT APPLICATION

ZONING PERMIT #: 2023 0622

NOTE: This application must be filled out completely and all components of submission requirements must be met before the application can be accepted and scheduled for review/hearing.

ZONING ACTIVITY: New Construction Alteration/Repair Addition Sign (See Spec sheet)
(Check all that apply) New Tenant/Use Change of Use Relocation

NAME OF BUSINESS/APPLICANT: Mountain Spring Podiatry

PROPOSED USE: Outdoor Sign Size (Sq. Ft./Length) of Construction: 2' x 20'

SITE ADDRESS: 15100 Washington St Parcel ID #: _____

Subdivision Name: _____ Lot Size: _____

ZONING DISTRICT: R-1 R-2 B-1 B-2 I-1 C-1

Special Use Permit Required: Yes No Site Plan Required: Yes No

Off-street Parking: Spaces Required: _____ Spaces Provided: _____

BRIEF DESCRIPTION OF ACTIVITY: (i.e. previous use, height/length of fencing, deck specs, etc.)
Application of Exterior Signage for Business

Supporting Documentation (attached): Narrative Plan/Plat Specification Sheet

FEE: \$25.00 Residential \$50.00 Commercial

CERTIFICATE OF APPROPRIATENESS

ADDITIONAL DESCRIPTION: (i.e. color, type of material, font style, etc. See Sign Spec Sheet for Signage detail)

Supporting Documentation (attached): Specification Sheet Photograph(s)

PERMIT HOLDER INFORMATION		PROPERTY OWNER INFORMATION	
Name	<u>Alexander Kieger</u>	Name	<u>Mohammed Yaghi</u>
Address	<u>15100 Washington St</u>	Address	<u>940 Park St NE</u>
City	<u>Haymarket, VA</u>	City	<u>Vienna, VA</u>
State	<u>20169</u>	State	<u>22180</u>
Zip		Zip	
Phone#	<u>3018288649</u>	Phone#	<u>7035966596</u>
Email	<u>Alex.Kieger@gmail.com</u>	Email	<u>myaghi1999@yahoo.com</u>

Attachment: 02 Haymarket sign application Mountain Spring Podiatry - signed (6239 : ZP #2023-0622: Sign Permit - Mountain Spring Podiatry

APPLICANT / PROPERTY OWNER SIGNATURE

*******REQUIRED*******

I, as owner or authorized agent for the above-referenced parcel, do hereby certify that I have the authority to make the foregoing application and that the information provided herein is correct. Construction of improvements described herein and as shown on the attached plat, plan and/or specifications will comply with the ordinances of the Town of Haymarket and any additional restrictions and/or conditions prescribed by the Architectural Review Board (ARB), Planning Commission, or the Town Council and all other applicable laws.

Alexander Kieger (Jul 19, 2023 16:57 EDT)
Applicant Signature

M Yamin (Jul 19, 2023 16:59 EDT)
Property Owner Signature

*****OFFICE USE ONLY*****

Date Filed: 6/8/23 Fee Amount: 50 Date Paid: 6/8/23 CK 3279

DATE TO ZONING ADMINISTRATOR: 6/9/23

APPROVED DISAPPROVED TABLED UNTIL: _____ DEFERRED UNTIL: _____

SIGNATURE

PRINT

CONDITIONS:

DATE TO ARCHITECTURAL REVIEW BOARD (ARB): _____

APPROVED DISAPPROVED TABLED UNTIL: _____ DEFERRED UNTIL: _____

SIGNATURE

PRINT

CONDITIONS:

DATE TO TOWN COUNCIL (IF APPLICABLE): _____

APPROVED DISAPPROVED TABLED UNTIL: _____ DEFERRED UNTIL: _____

TOWN COUNCIL (where required):

SIGNATURE

PRINT

CONDITIONS:

Attachment: 02 Haymarket sign application Mountain Spring Podiatry - signed (6239 : ZP #2023-0622: Sign Permit - Mountain Spring Podiatry

SIGN SPECIFICATION SHEET

SIGN 1:

Type of Sign: Wall Hanging Freestanding Menu Individual Letter Window Other

Height above Ground at Signs: Lower Edge: 15' Upper Edge: 17'

Height of Sign Structure: 2' Sign Width: ~2' Length: ~6' Area in Sq Ft: 11.5 Sq Ft

Number of Faces: 1 Sign Material/Color/Font: Aluminum / Blue green / Channel

Location of Sign (Include photo): Front of Building

Lighting Type/Fixture (No internal illumination is allowed): N/A

SIGN 2:

Type of Sign: Wall Hanging Freestanding Menu Individual Letter Window Other

Height above Ground at Signs: Lower Edge: _____ Upper Edge: _____

Height of Sign Structure: _____ Sign Width: _____ Length: _____ Area in Sq Ft: _____

Number of Faces: _____ Sign Material/Color/Font: _____

Location of Sign (Include photo): _____

Lighting Type/Fixture (No internal illumination is allowed): _____

SIGN 3:

Type of Sign: Wall Hanging Freestanding Menu Individual Letter Window Other

Height above Ground at Signs: Lower Edge: _____ Upper Edge: _____

Height of Sign Structure: _____ Sign Width: _____ Length: _____ Area in Sq Ft: _____

Number of Faces: _____ Sign Material/Color/Font: _____

Location of Sign (Include photo): _____

Lighting Type/Fixture (No internal illumination is allowed): _____

SIGN 4:

Type of Sign: Wall Hanging Freestanding Menu Individual Letter Window Other

Height above Ground at Signs: Lower Edge: _____ Upper Edge: _____

Height of Sign Structure: _____ Sign Width: _____ Length: _____ Area in Sq Ft: _____

Number of Faces: _____ Sign Material/Color/Font: _____

Location of Sign (Include photo): _____

Lighting Type/Fixture (No internal illumination is allowed): _____

Attachment: 02 Haymarket sign application Mountain Spring Podiatry - signed (6239 : ZP #2023-0622: Sign Permit - Mountain Spring Podiatry









Haymarket sign application Mountain Spring Podiatry

Final Audit Report

2023-07-19

Created:	2023-07-19
By:	Kenneth Pasquale (ken@medicalworldsolutions.com)
Status:	Signed
Transaction ID:	CBJCHBCAABAA6CNHJJvNhCZtvwUTIIOkDMVbjHJZwb42

"Haymarket sign application Mountain Spring Podiatry" History

-  Document created by Kenneth Pasquale (ken@medicalworldsolutions.com)
2023-07-19 - 8:55:30 PM GMT
-  Document emailed to Alexander Kieger (alex.kieger@gmail.com) for signature
2023-07-19 - 8:56:25 PM GMT
-  Email viewed by Alexander Kieger (alex.kieger@gmail.com)
2023-07-19 - 8:56:30 PM GMT
-  Document e-signed by Alexander Kieger (alex.kieger@gmail.com)
Signature Date: 2023-07-19 - 8:57:52 PM GMT - Time Source: server
-  Document emailed to myaghi1999@yahoo.com for signature
2023-07-19 - 8:57:55 PM GMT
-  Email viewed by myaghi1999@yahoo.com
2023-07-19 - 8:58:45 PM GMT
-  Signer myaghi1999@yahoo.com entered name at signing as M Yaghi DDS
2023-07-19 - 8:59:56 PM GMT
-  Document e-signed by M Yaghi DDS (myaghi1999@yahoo.com)
Signature Date: 2023-07-19 - 8:59:58 PM GMT - Time Source: server
-  Agreement completed.
2023-07-19 - 8:59:58 PM GMT



KAPLAN
WEALTH MANAGEMENT

Mountain Spring
Podiatry

RE/MAX REAL ESTATE
CONNECTIONS

15100

RE/MAX
COME ON IN
WE ARE OPEN
RE/MAX REAL ESTATE CONNECTIONS
877-888-8888

Attachment: 03 Location of Signage along Washington St. edited image (6239 - ZP #2023-0622: Sign Permit - Mountain Spring Podiatry 15100 Washington St)



Town of Haymarket
15000 Washington Street, #100
Haymarket, VA 20169
703-753-2600

Thomas Britt
Town Planner

MEMORANDUM

TO: Architectural Review Board
FROM: Thomas Britt, Town Planner
DATE: July 19th, 2023
SUBJECT: Lifetime Smiles Elevations Application

Application Summary:

Applicant, John F Hetzel AIA, has submitted their architectural elevations for Haymarket Lifetime Smiles for consideration by the ARB. The property sits near the back of the Quarles property, between Chick Fil A and the future Kiddie Academy site. There is one sign that will be placed at the front façade of Lifetime Smiles, which will be applied for separately.

Color renderings, materials/paint samples, and pictures of the surrounding area have been provided for the Architectural Review Board's consideration.

The applicant has sent an updated exterior design package showing the three-sided brick façade as requested by the ARB. The applicant has also submitted a series of lighting options for the Board to consider with this application.

STAFF RECOMMENDATION:

Following a discussion on the designs, Staff recommends the ARB ask the applicant to clearly outline any fencing, trash, or other accessory exterior elements on the Lifetime Smiles parcel.

DRAFT MOTION:

"I make a motion to approve ZP #2023-0601: architectural elevations for Haymarket Lifetime Smiles. The elevation has been approved as follows ---."

Or An alternate motion.



ZONING PERMIT APPLICATION

ZONING PERMIT #: 2023-0601

NOTE: This application must be filled out completely and all components of submission requirements must be met before the application can be accepted and scheduled for review/hearing.

ZONING ACTIVITY: New Construction Alteration/Repair Addition Sign (See Spec sheet)
 (Check all that apply) New Tenant/Use Change of Use Relocation

NAME OF BUSINESS/APPLICANT: Lifetime Smiles

PROPOSED USE: Dentist Office Size (Sq. Ft./Length) of Construction: 5786 SF

SITE ADDRESS: 15180 Washington Street Parcel ID #: 7298-71-6222.01

Subdivision Name: Quarles Center Lot Size: .44766

ZONING DISTRICT: R-1 R-2 B-1 B-2 I-1 C-1

Special Use Permit Required: Yes No Site Plan Required: Yes No

Off-street Parking: Spaces Required: 30 Spaces Provided: 31

BRIEF DESCRIPTION OF ACTIVITY: (i.e. previous use, height/length of fencing, deck specs, etc.)

New wood framed building for dental office with brick veneer and siding, EIFS Cornices and a flat roof with white TPO.

Supporting Documentation (attached): Narrative Plan/Plat Specification Sheet

FEE: \$25.00 Residential \$50.00 Commercial

CERTIFICATE OF APPROPRIATENESS

ADDITIONAL DESCRIPTION: (i.e. color, type of material, font style, etc. See Sign Spec Sheet for Signage detail)

Brick veneer on front of building with storefront windows; brick water table with siding above on remaining 3 sides of building

Supporting Documentation (attached): Specification Sheet Photograph(s)

PERMIT HOLDER INFORMATION			PROPERTY OWNER INFORMATION		
Lifetime Smiles PLLC/Sina Reangber			Washington Street Real Estate Holdings LLC		
Name 5391 Merchants View Sq			Name 42052 Mansfield Park Ct		
Address Haymarket VA 20169			Address Chantilly VA 20152		
City 703 965 1977	State rahim.mansur@gmail.com	Zip	City 703 965 1977	State rahim.mansur@gmail.com	Zip
Phone#	Email		Phone#	Email	

Attachment: 02 zoning_permit_form-coa_updated_10-29-2014-signed (6227 : ZP #2023-0601: Exterior Elevations - Lifetime Smiles 15180

APPLICANT / PROPERTY OWNER SIGNATURE

*******REQUIRED*******

I, as owner or authorized agent for the above-referenced parcel, do hereby certify that I have the authority to make the foregoing application and that the information provided herein is correct. Construction of improvements described herein and as shown on the attached plat, plan and/or specifications will comply with the ordinances of the Town of Haymarket and any additional restrictions and/or conditions prescribed by the Architectural Review Board (ARB), Planning Commission, or the Town Council and all other applicable laws.

[Signature]
Applicant Signature

[Signature]
Property Owner Signature

*****OFFICE USE ONLY*****

Date Filed: _____ Fee Amount: _____ Date Paid: _____

DATE TO ZONING ADMINISTRATOR: _____

APPROVED DISAPPROVED TABLED UNTIL: _____ DEFERRED UNTIL: _____

SIGNATURE

PRINT

CONDITIONS:

DATE TO ARCHITECTURAL REVIEW BOARD (ARB): _____

APPROVED DISAPPROVED TABLED UNTIL: _____ DEFERRED UNTIL: _____

SIGNATURE

PRINT

CONDITIONS:

DATE TO TOWN COUNCIL (IF APPLICABLE): _____

APPROVED DISAPPROVED TABLED UNTIL: _____ DEFERRED UNTIL: _____

SIGNATURE

PRINT

TOWN COUNCIL {where required):

CONDITIONS:

J2 Engineers - X:\DRAWINGS\ACTIVE\Crossroads Village Center\CHICK-FIL-A REVISION\CHICK-FIL-A Utility EXHIBIT.dwg [EXHIBIT 245.35] January 18, 2023 - 9:52am sscbwppp

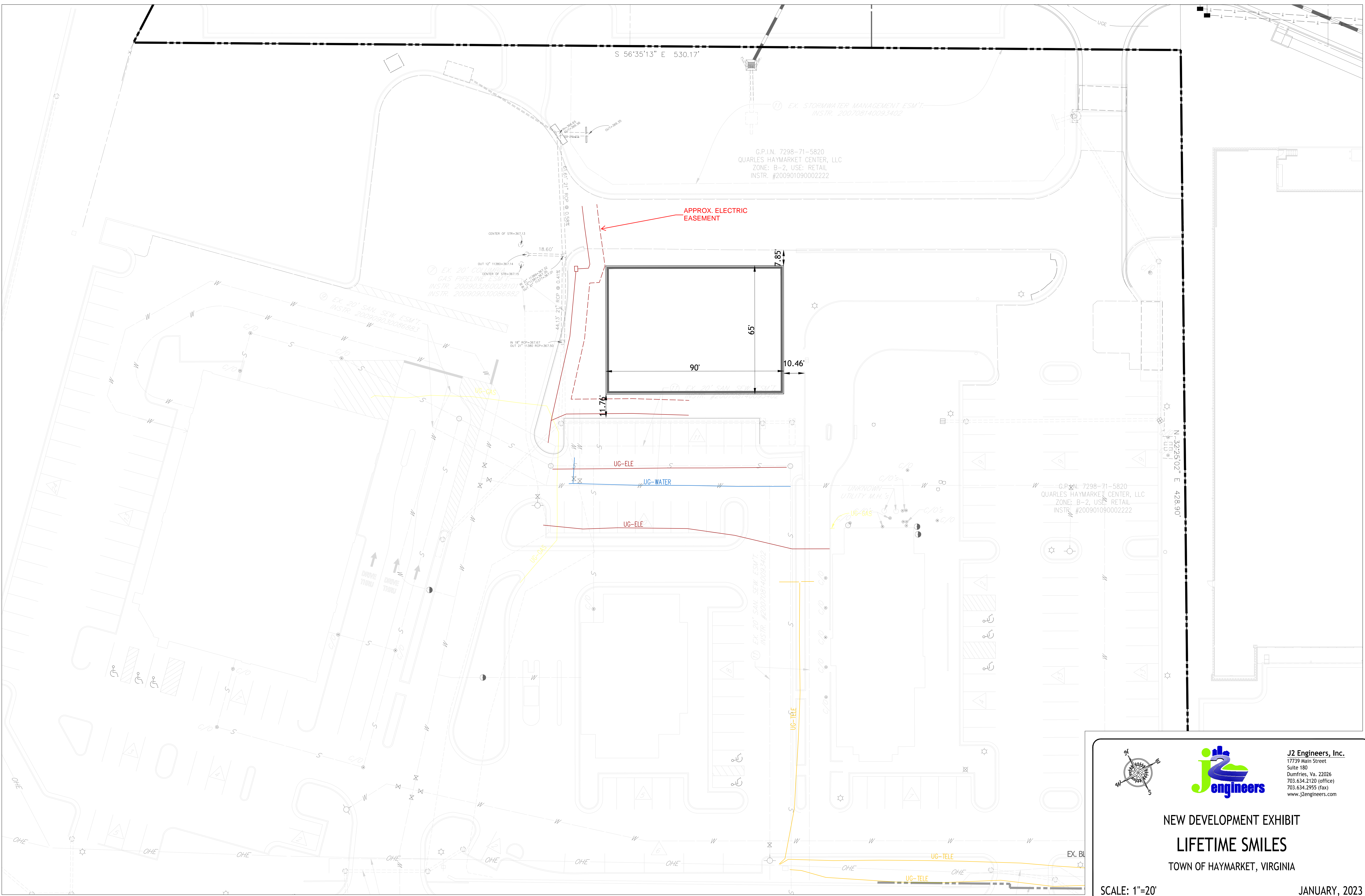

Attachment: 03 Site Exhibit (6227 - ZP #2023-0601: Exterior Elevations - Lifetime Smiles 15180 Washington Street)

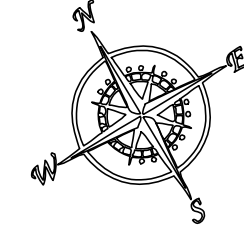



J2 Engineers, Inc.
 17739 Main Street
 Suite 180
 Dumfries, Va. 22026
 703.634.2120 (office)
 703.634.2955 (fax)
 www.j2engineers.com

NEW DEVELOPMENT EXHIBIT
LIFETIME SMILES
 TOWN OF HAYMARKET, VIRGINIA

SCALE: 1"=20'

JANUARY, 2023

← Haymarket, Virginia



Attachment: 04 Current Site Photo (6227 : ZP #2023-0601 : Exterior Elevations - Lifetime Smiles 15180

← 15190 VA-55 Haymarket, Virginia

Chick-fil-A ✕
 Chick-fil-A, 15180 Was...
 38.82°N, 77.64°W

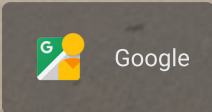
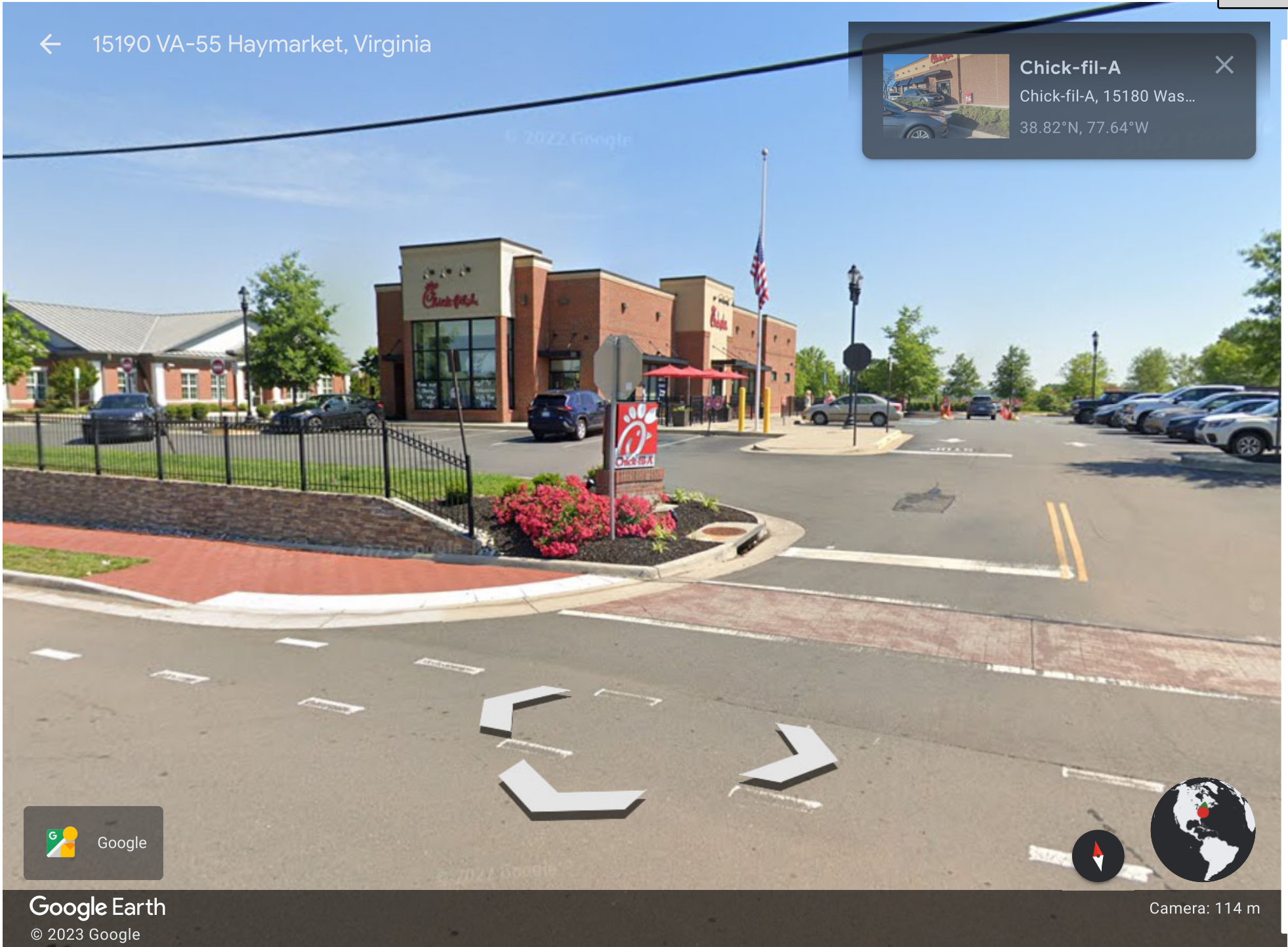
Google Earth
 © 2023 Google



Camera: 114 m

Attachment: 05 Adjacent Property Photos (6227 : ZP #2023-0601 : Exterior Elevations - Lifetime Smiles

← Photo Sphere



Virginia National ... ✕
 Virginia National Bank: ...
 38.82°N, 77.64°W

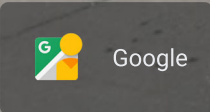

Google Earth
 © 2023 Google



Camera: 116 m

Attachment: 05 Adjacent Property Photos (6227 : ZP #2023-0601 : Exterior Elevations - Lifetime Smiles

← Haymarket, Virginia

 **Virginia National ...** ✕
 Virginia National Bank: ...
 38.82°N, 77.64°W

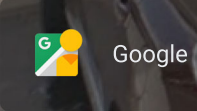

Google Earth
 © 2023 Google



Camera: 117 m

Attachment: 05 Adjacent Property Photos (6227 : ZP #2023-0601 : Exterior Elevations - Lifetime Smiles

← Haymarket, Virginia

 **Virginia National ...** ✕
 Virginia National Bank: ...
 38.82°N, 77.64°W



Google Earth
 © 2023 Google



Camera: 116 m

Attachment: 05 Adjacent Property Photos (6227 : ZP #2023-0601 : Exterior Elevations - Lifetime Smiles

← Haymarket, Virginia

 **Virginia National ...** ✕
 Virginia National Bank: ...
 38.82°N, 77.64°W



Google Earth
 © 2023 Google

Camera: 116 m

Attachment: 05 Adjacent Property Photos (6227 : ZP #2023-0601: Exterior Elevations - Lifetime Smiles 15180 Washington Street)

← Haymarket, Virginia



Virginia National ... ✕
 Virginia National Bank: ...
 38.82°N, 77.64°W



Google Earth
 © 2023 Google



Camera: 116 m

Attachment: 05 Adjacent Property Photos (6227 : ZP #2023-0601 : Exterior Elevations - Lifetime Smiles

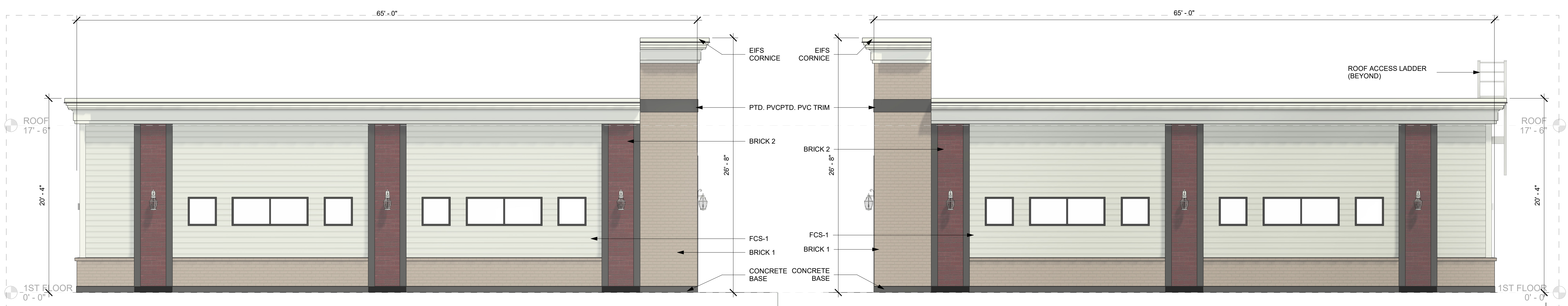

1 ARB - LEFT ELEVATION
3/16" = 1'-0"

2 ARB - RIGHT ELEVATION
3/16" = 1'-0"





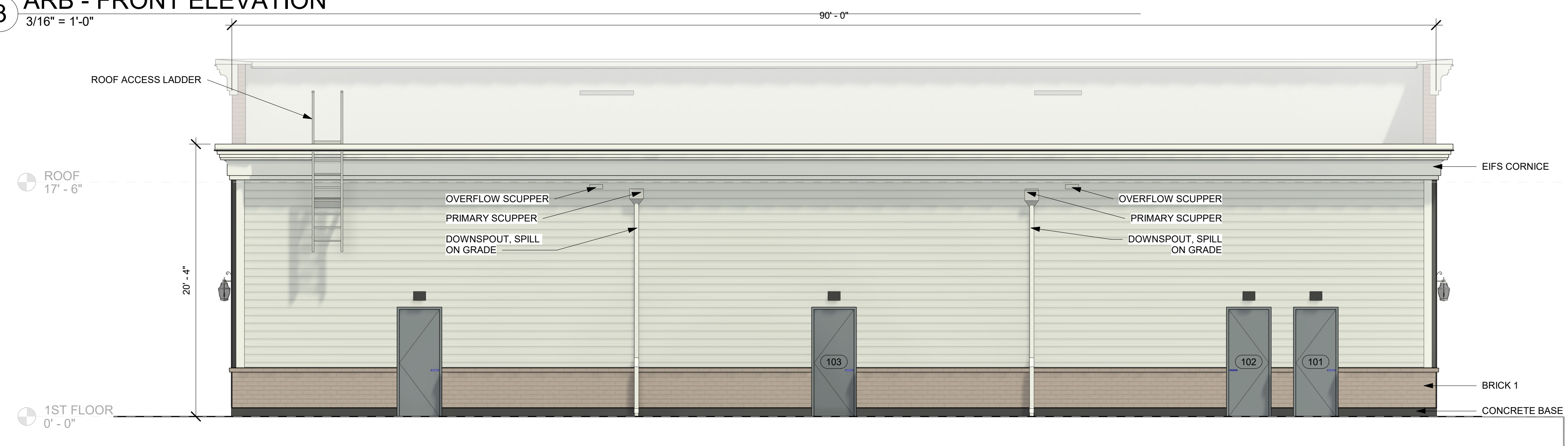



3 ARB - FRONT ELEVATION
3/16" = 1'-0"

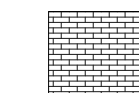
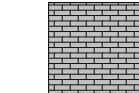

4 ARB - REAR ELEVATION
3/16" = 1'-0"

MATERIALS LEGEND:

-  BR-1 - STANDARD BRICK
MANUFACTURER: CONTINENTAL BRICK COMPANY
STYLE: STD. 481 MOD.
MORTAR COLOR: TBD
CONTACT: POTOMAC VALLEY BRICK & SUPPLY CO
703-868-0174
FMAYER@PVBRICK.COM
-  BR-2 - STANDARD BRICK
MANUFACTURER: SHENANDOAH
STYLE: CUSHIVA MODULAR
MORTAR COLOR: TBD
CONTACT: POTOMAC VALLEY BRICK & SUPPLY CO
703-868-0174
FMAYER@PVBRICK.COM
-  FCS-1 - FIBER CEMENT LAP SIDING
MANUFACTURER: JAMES HARDIE
STYLE: SELECT CEDARMILL 7" EXPOSURE
COLOR: ARCTIC WHITE
-  FT-1 - FIBERCEMENT TRIM
MANUFACTURER: JAMES HARDIE
PRODUCT: JAMES HARDIE TRIM BOARD
COLOR: ARCTIC WHITE
-  PVC-1 - PAINTED PVC TRIM
MANUFACTURER: AZEK EXTERIORS OR SIMILAR
PRODUCT: AZEK TRIM WITH PAINTPRO TECHNOLOGY
COLOR: BLACK FINISH COLOR: IN ACCORDANCE WITH MANUFACTURER'S RECOMMENDED PAINT
-  EIFS-1 - EIFS CORNICE
COLOR TO MATCH WHITE SIDING
-  CWB-1 - CONCRETE WALL BASE; PAINTED BLACK TO MATCH PVC TRIM
-  SF-1 - STOREFRONT BLACK ALUMINUM FINISH



John F. Heltzel
AIA
A PROFESSIONAL CORPORATION

9389 FORESTWOOD LANE
MANASSAS, VIRGINIA 20110
PHONE 703-330-6170
FAX 703-361-8671
WWW.HELTELZAIA.COM

LIFETIME SMILES
NEW SHELL BUILDING
15180 WASHINGTON ST.,
HAYMARKET, VA 20169

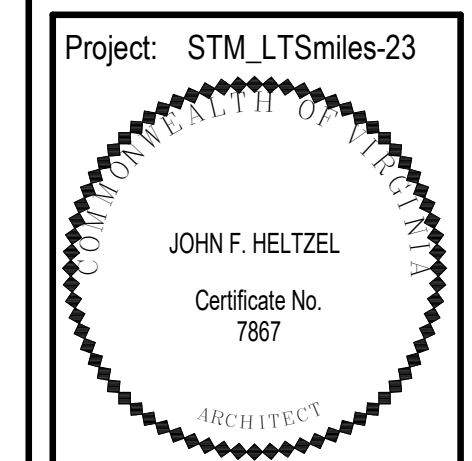

Project: STM_LTSmiles-23
CD
DATE: 07/10/23
REVISIONS

SHEET
Unnamed Copy 1
ARB-2

Attachment: 07 Updated Elevations with 3-sided Brick Facade (6227 - ZP #2023-0601: Exterior Elevations - Lifetime Smiles 15180 Washington Street)

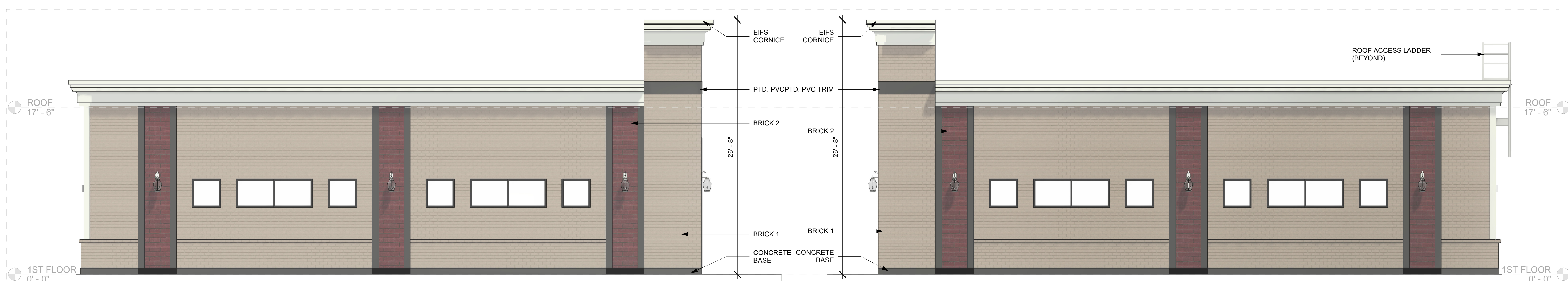

1 ARB - LEFT ELEVATION - BRICK ON 3 SIDES
3/16" = 1'-0"

2 ARB - RIGHT ELEVATION - BRICK ON 3 SIDES
3/16" = 1'-0"



3 ARB - FRONT ELEVATION - BRICK ON 3 SIDES
3/16" = 1'-0"



4 ARB - REAR ELEVATION - BRICK ON 3 SIDES
3/16" = 1'-0"

MATERIALS LEGEND:

- BR-1 - STANDARD BRICK
MANUFACTURER: CONTINENTAL BRICK COMPANY
STYLE: STD. 481 MOD.
MORTAR COLOR: TBD
CONTACT: POTOMAC VALLEY BRICK & SUPPLY CO
703-868-0174
FMAYER@PVBICK.COM
- BR-2 - STANDARD BRICK
MANUFACTURER: SHENANDOAH
STYLE: CUSHIVA MODULAR
MORTAR COLOR: TBD
CONTACT: POTOMAC VALLEY BRICK & SUPPLY CO
703-868-0174
FMAYER@PVBICK.COM
- FCS-1 - FIBER CEMENT LAP SIDING
MANUFACTURER: JAMES HARDIE
STYLE: SELECT CEDARMILL 7" EXPOSURE
COLOR: ARCTIC WHITE
- FIBERCEMENT TRIM
MANUFACTURER: JAMES HARDIE
PRODUCT: JAMES HARDIE TRIM BOARD
COLOR: ARCTIC WHITE
- PAINTED PVC TRIM
MANUFACTURER: AZEK EXTERIORS OR SIMILAR
PRODUCT: AZEK TRIM WITH PAINTPRO TECHNOLOGY
COLOR: BLACK FINISH COLOR: IN ACCORDANCE WITH MANUFACTURER'S RECOMMENDED PAINT
- EIFS CORNICE
COLOR TO MATCH WHITE SIDING
- CONCRETE WALL BASE; PAINTED BLACK TO MATCH PVC TRIM
- STOREFRONT BLACK ALUMINUM FINISH

PLANS NOT FOR CONSTRUCTION UNLESS THEY ARE BEARING THE DOCUMENTED APPROVAL(S) BY THE BUILDING PERMIT DEPARTMENT OF THE APPLICABLE JURISDICTION.

7/11/2023 10:57:48 AM
C:\Users\Heather\John F. Heltzel AIA PC\UFH AIA PC - Projects\STM_LTSmiles-23\CAD Files\STM-Lifetime Smiles.rvt

COPYRIGHT JOHN F. HELTZEL AIA, PC 2022

DOWNSPOUT
METAL COPING
PAC CLAD

SW 6237
Cherry
PAINT Rear doors & frame

SW 6258
Tricorn Black
257-C7
PAINT PVC TRIM

STORE FRONT
SF-1

SW 6231
Rock Candy
257-C6
EIFS-1

FCS-1 FIBER CEMENT

Continental Brick Company
154 Charles Town Road
Martinsburg, West Virginia 25405
(304) 263-6974 • Fax (304) 267-0793

IMPORTANT NOTICE
IT IS IMPOSSIBLE WITH ONLY A FEW BRICK TO ILLUSTRATE ALL COLORS, COLOR PERCENTAGES AND HARMLESS IMPERFECTIONS THAT MAY OCCUR IN A FULL BRICK SHIPMENT. THEREFORE, THIS SAMPLE IS INTENDED TO REPRESENT GENERAL COLOR RANGE AND TEXTURE ONLY.

BR-1



Std. 481 Mod.

POTOMAC VALLEY BRICK AND SUPPLY CO.
Corporate: 301-509-9600
Baltimore, MD: 410-682-6700
Edwards, MD: 410-488-9666
Frederick, MD: 301-297-8015

Edwards, MD: 410-488-9666
Frederick, MD: 301-297-8015



POTOMAC VALLEY BRICK AND SUPPLY CO.
Corporate: 301-509-9600
Baltimore, MD: 410-682-6700
Edwards, MD: 410-488-9666
Frederick, MD: 301-297-8015

IMPORTANT NOTICE
IT IS IMPOSSIBLE WITH ONLY A FEW BRICK TO ILLUSTRATE ALL COLORS, COLOR PERCENTAGES AND HARMLESS IMPERFECTIONS THAT MAY OCCUR IN A FULL BRICK SHIPMENT. THEREFORE, THIS SAMPLE IS INTENDED TO REPRESENT GENERAL COLOR RANGE AND TEXTURE ONLY.

Cushwa



SHENANDOAH
Modular

BR-2





ARC1 LED

Architectural Wall Luminaire

Catalog
Number

Notes

Type

Hit the Tab key or mouse over the page to see all interactive elements.

Specifications

Depth (D1):	6.5"
Depth (D2):	4.75"
Height:	5"
Width:	11"
Weight: (without options)	7 lbs

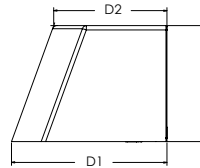
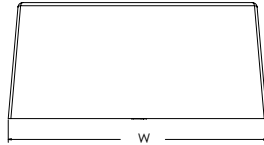

Introduction

The Lithonia Lighting ARC LED wall-mounted luminaires provide both architectural styling and visually comfortable illumination while providing the high energy savings and low initial costs for quick financial payback.

ARC1 delivers up to 3,000 lumens with a soft, non-pixelated light source, creating a visually comfortable environment. The compact size of ARC1, with its integrated emergency battery backup option, is ideal for over-the-door applications.

ARC LED Family Overview

Luminaire	Standard EM, 0°C	Cold EM, -20°C	Approximate Lumens (4000K)				
			P1	P2	P3	P4	P5
ARC1 LED	4W	--	1,500	2,000	3,000	--	--
ARC2 LED	4W	8W	1,500	2,000	3,000	4,000	6,500

Ordering Information

EXAMPLE: ARC1 LED P2 40K MVOLT PE DDBXD

Series	Package	Color Temperature	Voltage	Options	Finish
ARC1 LED	P1 1,500 Lumens	30K 3000K	MVOLT 347 ¹	E4WH Emergency battery backup, CEC compliant (4W, 0°C min) ¹	DDBXD Dark bronze
	P2 2,000 Lumens	40K 4000K		PE Button type photocell for dusk-to-dawn operation	DBLXD Black
	P3 3,000 Lumens	50K 5000K		DMG 0-10V dimming wires pulled outside fixture (for use with an external control, ordered separately) ²	DNAXD Natural aluminum
				SPD6KV 6kV surge protection	DWHXD White
				FAO Field adjustable light output device. Allows for easy adjustment to the desired light levels, from 20% to 100% ²	DSSXD Sandstone
					DDBTXD Textured dark bronze
					DBL BXD Textured black
					DNATXD Textured natural aluminum
					DWHGXD Textured white
					DSSTXD Textured sandstone

Accessories

Ordered and shipped separately.

WSBBW DDBXD U Surface - mounted back box (specify finish)

NOTES

- 347V not available with E4WH
- FAO not available with DMG.



COMMERCIAL OUTDOOR

One Lithonia Way • Conyers, Georgia 30012 • Phone: 1-800-705-SERV (7378) • www.lithonia.com
© 2020-2022 Acuity Brands Lighting, Inc. All rights reserved.

ARC1 LED
Rev. 03/02/22

Packet Pg. 37

Performance Data

Lumen Output

Lumen values are from photometric tests performed in accordance with IESNA LM-79-08. Data is considered to be representative of the configurations shown, within the tolerances allowed by Lighting Facts. Contact factory for performance data on any configurations not shown here.

Performance Package	System Watts	30K (3000K, 80 CRI)					40K (4000K, 80 CRI)					50K (5000K, 80 CRI)				
		Lumens	LPW	B	U	G	Lumens	LPW	B	U	G	Lumens	LPW	B	U	G
P1	11W	1,376	127	0	0	0	1,454	134	0	0	0	1,464	135	0	0	0
P2	17W	2,035	121	1	0	1	2,151	128	1	0	1	2,165	129	1	0	1
P3	25W	2,859	117	1	0	1	3,021	123	1	0	1	3,041	124	1	0	1

Electrical Load

Performance Package	System Watts	Current (A)				
		120V	208V	240V	277V	347V
P1	11W	0.111	0.061	0.053	0.047	0.045
P2	17W	0.139	0.081	0.071	0.063	0.060
P3	25W	0.208	0.122	0.108	0.097	0.081

Lumen Output in Emergency Mode (4000K, 80 CRI)

Option	Lumens
E4WH	620

Lumen Ambient Temperature (LAT) Multipliers

Use these factors to determine relative lumen output for average ambient temperatures from 0-40°C (32-104°F).

Ambient		Lumen Multiplier
0°C	32°F	1.04
10°C	50°F	1.02
20°C	68°F	1.01
25°C	77°F	1.00
30°C	86°F	0.99
40°C	104°F	0.97

Projected LED Lumen Maintenance

Data references the extrapolated performance projections for the platforms noted in a 25°C ambient, based on 10,000 hours of LED testing (tested per IESNA LM-80-08 and projected per IESNA TM-21-11). To calculate LLF, use the lumen maintenance factor that corresponds to the desired number of operating hours below. For other lumen maintenance values, contact factory.

Operating Hours	0	25,000	50,000	100,000
Lumen Maintenance Factor	0.97	>0.96	>0.95	>0.91

Photometric Diagrams

To see complete photometric reports or download .ies files for this product, visit the Lithonia Lighting ARC LED homepage. Tested in accordance with IESNA LM-79 and LM-80 standards.

LEGEND

■	0.25 fc
■	0.5 fc
■	1.0 fc
■	3.0 fc

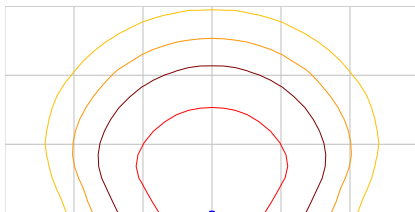

MH = 10ft
Grid = 10ft x 10ft

ARC1 LED P3 40K

Emergency Egress Options

Emergency Battery Backup

The emergency battery backup is integral to the luminaire — no external housing required! This design provides reliable emergency operation while maintaining the aesthetics of the product. All emergency battery backup configurations include an independent secondary driver with an integral relay to immediately detect loss of normal power and automatically energize the luminaire. The emergency battery will power the luminaire for a minimum duration of 90 minutes (maximum duration of three hours) from the time normal power is lost and maintain a minimum of 60% of the light output at the end of 90 minutes.

Applicable codes: NFPA 70/NEC – section 700.16, NFPA 101 Life Safety Code Section 7.9

The example below shows illuminance of 1 fc average and 0.1 fc minimum in emergency mode.

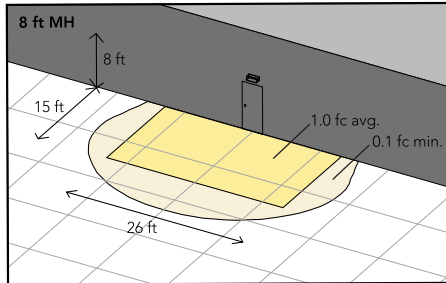

Grid = 10ft x 10ft

ARC1 LED 40K MVOLT E4WH

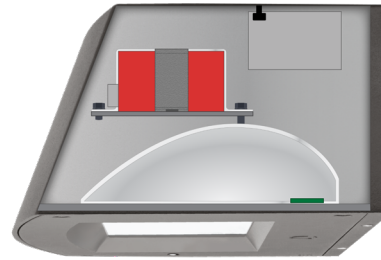

Self-contained solution for clean aesthetic

Mounting, Options & Accessories



E4WH – 4W Emergency Battery Backup

D = 6.5"

H = 5"

W = 11"

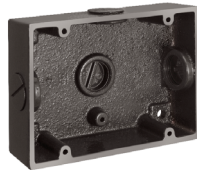

BBW – Standard Back Box

D = 1.5"

H = 4"

W = 5.5"

For surface conduit applications.
3/4" conduit entry holes.

FEATURES & SPECIFICATIONS

INTENDED USE

The clean architectural shape of the ARC LED was designed for applications such as hospitals, schools, malls, restaurants, and commercial buildings. The long-life LEDs and driver make this luminaire nearly maintenance-free.

CONSTRUCTION

The die-cast aluminum housing and door act as heat sinks to optimize thermal transfer from the light engine and driver to promote long-life. The die-cast door frame is fully gasketed with a one-piece solid silicone gasket to keep out moisture and dust, providing an IP65 rating for the luminaire.

FINISH

Exterior painted parts are protected by a zinc-infused Super Durable TGIC thermoset powder coat finish that provides superior resistance to corrosion and weathering. A tightly controlled multi-stage process ensures a 3 mils thickness for a finish that can withstand extreme climate changes without cracking or peeling. Standard Super Durable colors include dark bronze, black, natural aluminum, sandstone and white. Available in textured and non-textured finishes.

OPTICS

Recessed lens to cut off high angle light and reduce glare. Combination of diffused lens and reflector design has low surface brightness creating a visually comfortable environment with great distribution. LEDs are fully hidden from view to eliminate pixelization and harsh glare. The ARC LED has zero uplight and qualifies as a Nighttime Friendly™ product, meaning it is consistent with the LEED® and Green Globes™ criteria for eliminating wasteful uplight.

ELECTRICAL

Light engine consists of high-efficiency LEDs mounted to metal-core circuit boards to maximize heat dissipation and promote long-life (up to L91/100,000 hours at 25°C). The electronic driver has a power factor of >90%, THD <20%. Luminaire is 0-10V dimmable.

INSTALLATION

The universal wall plate, supplied with the luminaire, fits multiple size junction boxes and supports the luminaire during wiring for easy installation. Built-in wet location wiring compartment on the luminaire to accommodate wiring connections for where there is no junction box. Design can withstand up to a 1.5 G vibration load rating per ANSI C136.31.

LISTINGS

CSA certified to U.S. and Canadian standards. Luminaire is IP65 rated. DesignLights Consortium® (DLC) Premium qualified product and DLC qualified product. Not all version of this product may be DLC Premium qualified or DLC qualified. Please check the DLC Qualified Products List at www.designlights.org/QPL to confirm which versions are qualified. International DarkSky Association (IDA) Fixture Seal of Approval (FSA) is available for all products on this page utilizing 3000K color temperature only. Rated for -40°C minimum ambient.

WARRANTY

5-year limited warranty. This is the only warranty provided and no other statements in this specification sheet create any warranty of any kind. All other express and implied warranties are disclaimed. Complete warranty terms located at: www.acuitybrands.com/support/warranty/terms-and-conditions

Note: Actual performance may differ as a result of end-user environment and application. All values are design or typical values, measured under laboratory conditions at 25 °C. Specifications subject to change without notice.



COMMERCIAL OUTDOOR

One Lithonia Way • Conyers, Georgia 30012 • Phone: 1-800-705-SERV (7378) • www.lithonia.com
© 2020-2022 Acuity Brands Lighting, Inc. All rights reserved.

ARC1 LED
Rev. 03/02/22

Packet Pg. 39

SPECIFICATIONS

Certifications/Qualifications

Title 24 Compliant	Yes www.kichler.com/warranty
--------------------	---

Dimensions

Base Backplate	4.50" X 5.50"
Extension	8.25"
Weight	3.50 LBS
Height from center of Wall opening (Spec Sheet)	6.75"
Height	16.75"
Width	7.50"

Electrical

Input Voltage	Single(120)V
---------------	--------------

Light Source

Delivered Lumens	850
Dimmable	Yes
Dimmable Notes	This LED is compatible with most standard incandescent dimmers, LED dimmers, and electronic low voltage dimmers. For more information, go to Kichler.com/dimming .
Expected Life Span (Hours)	20000
Lamp Included	Integrated
Light Source	LED
Max or Nominal Watt	8.00
# of Bulbs/LED Modules	1

Mounting/Installation

Interior/Exterior	Exterior
Location Rating	Wet
Mounting Style	Wall Mount
Mounting Weight	3.50 LBS

Photometrics

Color Rendering Index	90
Color Temperature Range	3000
Delivered Efficacy (Lumens/Watt)	59
Kelvin Temperature	2700K

FIXTURE ATTRIBUTES

Housing

Diffuser Description	Clear Seeded
Primary Material	Brass

Product/Ordering Information

SKU	9708OZLED
Finish	Olde Bronze
Style	Traditional
UPC	783927434515

Finish Options



Olde Bronze



ALSO IN THIS FAMILY



9708OZ



9909BK



9709BK



9708BK



9707OZ



9709OZ

Attachment: 11 Mount Vernon (6227 : ZP #2023-0601: Exterior Elevations - Lifetime Smiles 15180 Washington Street)

SPECIFICATIONS

Certifications/Qualifications

Class 2	Yes
Title 24 Compliant	Yes
	www.kichler.com/warranty

Dimensions

Base Backplate	16.00" X 8.00"
Extension	15.25"
Weight	20.00 LBS
Height from center of Wall opening (Spec Sheet)	14.00"
Height	29.50"
Width	10.50"

Electrical

Input Voltage	Single(120)V
---------------	--------------

Light Source

Delivered Lumens	900
Dimmable	Yes
Dimmable Notes	This LED is compatible with most standard incandescent dimmers, LED dimmers, and electronic low voltage dimmers. For more information, go to Kichler.com/dimming .

Equivalent Light Source	Incandescent
Expected Life Span (Hours)	40000
Lamp Included	Integrated
Light Source	LED
Max or Nominal Watt	25.00
# of Bulbs/LED Modules	1

Mounting/Installation

Interior/Exterior	Exterior
Location Rating	Wet
Mounting Weight	15.50 LBS

Photometrics

Color Rendering Index	90
Kelvin Temperature	3000K

FIXTURE ATTRIBUTES

Housing

Diffuser Description	Clear Vertical Rain
Primary Material	Aluminum
Shade Dimensions	10.50" D X 16.00"

Product/Ordering Information

SKU	49753BKTLED
Finish	Textured Black
Style	Traditional
UPC	783927493079

Finish Options

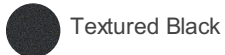

ALSO IN THIS FAMILY



49751BKTLED



49752BKTLED



49756BKTLED

Attachment: 12 Wakefield (6227 : ZP #2023-0601: Exterior Elevations - Lifetime Smiles 15180 Washington Street)

SPECIFICATIONS

Certifications/Qualifications

Title 24 Compliant	Yes www.kichler.com/warranty
--------------------	---

Dimensions

Base Backplate	14.50" X 7.75"
Extension	8.50"
Weight	4.00 LBS
Height from center of Wall opening (Spec Sheet)	2.25"
Height	14.50"
Width	7.75"

Electrical

Input Voltage	Single(120)V
---------------	--------------

Light Source

Delivered Lumens	375
Dimmable	Yes
Expected Life Span (Hours)	40000
Lamp Included	Integrated
Light Source	LED
Max or Nominal Watt	8.00
# of Bulbs/LED Modules	1

Mounting/Installation

Interior/Exterior	Exterior
Location Rating	Wet
Mounting Style	Wall Mount
Mounting Weight	3.20 LBS

Photometrics

Color Rendering Index	90
Kelvin Temperature	3000K

FIXTURE ATTRIBUTES

Housing

Diffuser Description	White Acrylic.
Primary Material	Aluminum
Shade Dimensions	8.00" SQ X 12.50"

Product/Ordering Information

SKU	49899BKLED
Finish	Black
Style	Transitional
UPC	783927540353

Finish Options



Black



ALSO IN THIS FAMILY



49898BKLED

Attachment: 13 Kent (6227 : ZP #2023-0601: Exterior Elevations - Lifetime Smiles 15180 Washington Street)

SPECIFICATIONS

Certifications/Qualifications

www.kichler.com/warranty

Dimensions

Base Backplate	6.25" X 12.00"
Extension	12.00"
Weight	7.50 LBS
Height from center of Wall opening (Spec Sheet)	6.00"
Height	22.50"
Width	8.50"

Light Source

Delivered Lumens	850
Dimmable	Yes
Expected Life Span (Hours)	40000
Lamp Included	Integrated
Light Source	LED
# of Bulbs/LED Modules	1
Socket Wire	105"

Mounting/Installation

Interior/Exterior	Exterior
Lead Wire Length	6"
Location Rating	Wet
Mounting Style	Wall Mount
Mounting Weight	5.25 LBS

Photometrics

Color Rendering Index	90
Kelvin Temperature	3000K

FIXTURE ATTRIBUTES

Housing

Diffuser Description	Satin Etched Cased Opal
Primary Material	Aluminum
Shade Dimensions	5.55" D X 13.30" H

Product/Ordering Information

SKU	59072BKLED
Finish	Black
Style	Contemporary
UPC	783927602167

Finish Options

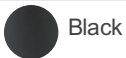

Black



ALSO IN THIS FAMILY



59070BKLED



59071BKLED



59073BKLED

Attachment: 14 Drega (6227 : ZP #2023-0601: Exterior Elevations - Lifetime Smiles 15180 Washington Street)



WEDGE1 LED

Architectural Wall Sconce

Catalog
Number

Notes

Type

Hit the Tab key or mouse over the page to see all interactive elements.

Specifications

Depth (D1):	5.5"
Depth (D2):	1.5"
Height:	8"
Width:	9"
Weight: (without options)	9 lbs

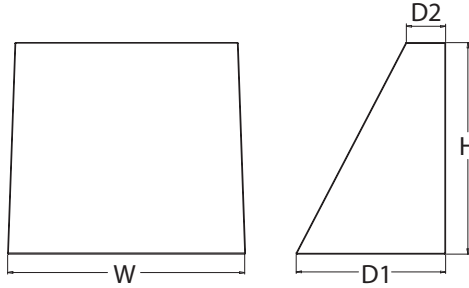

Introduction

The WEDGE LED family is designed to meet specifier's every wall-mounted lighting need in a widely accepted shape that blends with any architecture. The clean rectilinear design comes in four sizes with lumen packages ranging from 1,200 to 25,000 lumens, providing true site-wide solution.

WEDGE1 delivers up to 2,000 lumens with a soft, non-pixelated light source, creating a visually comfortable environment. The compact size of WEDGE1, with its integrated emergency battery backup option, makes it an ideal over-the-door wall-mounted lighting solution.

WEDGE LED Family Overview

Luminaire	Standard EM, 0°C	Cold EM, -20°C	Sensor	Lumens (4000K)					
				P1	P2	P3	P4	P5	P6
WEDGE1 LED	4W	--	--	1,200	2,000	--	--	--	--
WEDGE2 LED	10W	18W	Standalone / nLight	1,200	2,000	3,000	4,500	6,000	--
WEDGE3 LED	15W	18W	Standalone / nLight	7,500	8,500	10,000	12,000	--	--
WEDGE4 LED	--	--	Standalone / nLight	12,000	16,000	18,000	20,000	22,000	25,000

Ordering Information

EXAMPLE: WEDGE1 LED P2 40K 80CRI VF MVOLT SRM PE DDBXD

Series	Package	Color Temperature	CRI	Distribution	Voltage	Mounting
WEDGE1 LED	P1 P2	27K 2700K	80CRI	VF Visual comfort forward throw	MVOLT 347 ²	Shipped included SRM Surface mounting bracket ICW Indirect Canopy/Ceiling Washer bracket (dry/damp locations only) ⁵ Shipped separately AWS 3/8inch Architectural wall spacer PBBW Surface-mounted back box (top, left, right conduit entry) Use when there is no junction box available.
		30K 3000K	90CRI	VW Visual comfort wide		
		35K 3500K				
		40K 4000K				
		50K ¹ 5000K				

Options	Finish
E4WH ³ Emergency battery backup, Certified in CA Title 20 MAEDBS (4W, 0°C min)	DDBXD Dark bronze
PE ⁴ Photocell, Button Type	DBLXD Black
DS Dual switching (comes with 2 drivers and 2 light engines; see page 3 for details)	DNAXD Natural aluminum
DMG 0-10V dimming wires pulled outside fixture (for use with an external control, ordered separately)	DWHXD White
BCE Bottom conduit entry for back box (PBBW). Total of 4 entry points.	DSSXD Sandstone
BAA Buy America(n) Act Compliant	DDBTXD Textured dark bronze
	DBLBXD Textured black
	DNATXD Textured natural aluminum
	DWHGXD Textured white
	DSSTXD Textured sandstone

Accessories

Ordered and shipped separately.

WDGEAWS DDBXD	WEDGE 3/8inch Architectural Wall Spacer (specify finish)
WDGE1PBBW DDBXD U	WEDGE1 surface-mounted back box (specify finish)

NOTES

- 50K not available in 90CRI.
- 347V not available with E4WH, DS or PE.
- E4WH not available with PE or DS.
- PE not available with DS.
- Not qualified for DLC. Not available with E4WH.



COMMERCIAL OUTDOOR

One Lithonia Way • Conyers, Georgia 30012 • Phone: 1-800-705-SERV (7378) • www.lithonia.com
© 2019-2022 Acuity Brands Lighting, Inc. All rights reserved.

WEDGE1 LED
Rev. 11/21/22

Packet Pg. 44

Performance Data

Lumen Output

Lumen values are from photometric tests performed in accordance with IESNA LM-79-08. Data is considered to be representative of the configurations shown, within the tolerances allowed by Lighting Facts. Contact factory for performance data on any configurations not shown here.

Performance Package	System Watts	Dist. Type	27K (2700K, 80 CRI)					30K (3000K, 80 CRI)					35K (3500K, 80 CRI)					40K (4000K, 80 CRI)					50K (5000K, 80 CRI)				
			Lumens	LPW	B	U	G	Lumens	LPW	B	U	G	Lumens	LPW	B	U	G	Lumens	LPW	B	U	G	Lumens	LPW	B	U	G
P1	10W	VF	1,120	112	0	0	0	1,161	116	0	0	0	1,194	119	0	0	0	1,227	123	0	0	0	1,235	123	0	0	0
		VW	1,122	112	0	0	0	1,163	116	0	0	0	1,196	120	0	0	0	1,229	123	0	0	0	1,237	124	0	0	0
P2	15W	VF	1,806	120	1	0	0	1,872	125	1	0	0	1,925	128	1	0	0	1,978	132	1	0	0	1,992	133	1	0	0
		VW	1,809	120	1	0	0	1,876	125	1	0	0	1,929	128	1	0	0	1,982	132	1	0	0	1,996	133	1	0	0

Electrical Load

Performance Package	System Watts	Current (A)				
		120V	208V	240V	277V	347V
P1	10W	0.082	0.049	0.043	0.038	--
	13W	--	--	--	--	0.046
P2	15W	0.132	0.081	0.072	0.064	--
	18W	--	--	--	--	0.056

Lumen Multiplier for 90CRI

CCT	Multiplier
27K	0.845
30K	0.867
35K	0.845
40K	0.885
50K	0.898

Lumen Output in Emergency Mode (4000K, 80 CRI)

Option	Dist. Type	Lumens
E4WH	VF	646
	VW	647

Lumen Ambient Temperature (LAT) Multipliers

Use these factors to determine relative lumen output for average ambient temperatures from 0-40°C (32-104°F).

Ambient	Lumen Multiplier
0°C / 32°F	1.03
10°C / 50°F	1.02
20°C / 68°F	1.01
25°C / 77°F	1.00
30°C / 86°F	0.99
40°C / 104°F	0.98

Projected LED Lumen Maintenance

Data references the extrapolated performance projections for the platforms noted in a 25°C ambient, based on 10,000 hours of LED testing (tested per IESNA LM-80-08 and projected per IESNA TM-21-11).

To calculate LLF, use the lumen maintenance factor that corresponds to the desired number of operating hours below. For other lumen maintenance values, contact factory.

Operating Hours	0	25,000	50,000	100,000
Lumen Maintenance Factor	1.0	>0.96	>0.95	>0.91

Photometric Diagrams

To see complete photometric reports or download .ies files for this product, visit the Lithonia Lighting WDGE LED homepage. Tested in accordance with IESNA LM-79 and LM-80 standards.

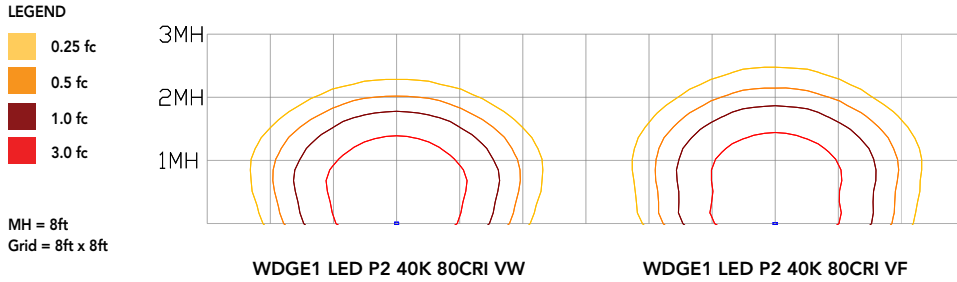

Emergency Egress Options

Emergency Battery Backup

The emergency battery backup is integral to the luminaire — no external housing required! This design provides reliable emergency operation while maintaining the aesthetics of the product. All emergency battery backup configurations include an independent secondary driver with an integral relay to immediately detect loss of normal power and automatically energize the luminaire. The emergency battery will power the luminaire for a minimum duration of 90 minutes (maximum duration of three hours) from the time normal power is lost and maintain a minimum of 60% of the light output at the end of 90 minutes.

Applicable codes: NFPA 70/NEC – section 700.16, NFPA 101 Life Safety Code Section 7.9

The example below shows illuminance of 1 fc average and 0.1 fc minimum in emergency mode with E4WH and VF distribution.

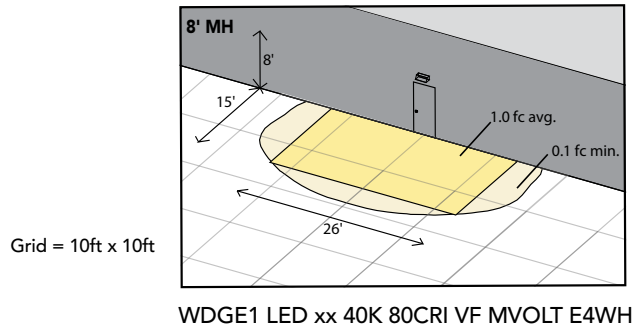

Dual Switching (DS) Option

The dual switching option offers operational redundancy that certain codes require. With this option the luminaire comes integrated with two drivers and two light engines. These work completely independent to each other so that a failure of any individual component does not cause the whole luminaire to go dark. This option is typically used with a back generator or inverter providing emergency power.

Applicable codes: NFPA 70/NEC – section 700.16, NFPA 101 Life Safety Code Section 7.9

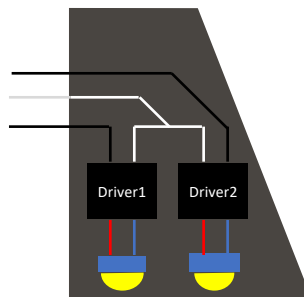

Attachment: 15 wdge1-led (6227 : ZP #2023-0601: Exterior Elevations - Lifetime Smiles 15180 Washington Street)

**E4WH – 4W Emergency Battery Backup**

D = 5.5"

H = 8"

W = 9"

**PBBW – Surface-Mounted Back Box****Use when there is no junction box available.**

D = 1.75"

H = 8"

W = 9"

**AWS – 3/8inch Architectural Wall Spacer**

D = 0.38"

H = 4.4"

W = 7.5"

FEATURES & SPECIFICATIONS**INTENDED USE**

Common architectural look, with clean rectilinear shape, of the WDGE LED was designed to blend with any type of construction, whether it be tilt-up, frame or brick. Applications include commercial offices, warehouses, hospitals, schools, malls, restaurants, and other commercial buildings.

CONSTRUCTION

The single-piece die-cast aluminum housing integrates secondary heat sinks to optimize thermal transfer from the internal light engine heat sinks and promote long life. The driver is mounted in direct contact with the casting for a low operating temperature and long life. The die-cast door frame is fully gasketed with a one-piece solid silicone gasket to keep out moisture and dust, providing an IP66 rating for the luminaire.

FINISH

Exterior painted parts are protected by a zinc-infused Super Durable TGIC thermoset powder coat finish that provides superior resistance to corrosion and weathering. A tightly controlled multi-stage process ensures a 3 mils thickness for a finish that can withstand extreme climate changes without cracking or peeling. Standard Super Durable colors include dark bronze, black, natural aluminum, sandstone and white. Available in textured and non-textured finishes.

OPTICS

Well crafted reflector optics allow the light engine to be recessed within the luminaire, providing visual comfort, superior distribution, uniformity, and spacing in wall-mount applications. The WDGE LED has zero uplight and qualifies as a Nighttime Friendly™ product, meaning it is consistent with the LEED® and Green Globes™ criteria for eliminating wasteful uplight.

ELECTRICAL

Light engine consists of high-efficiency LEDs mounted to metal-core circuit boards to maximize heat dissipation and promote long life (up to L91/100,000 hours at 25°C). The electronic driver has a power factor of >90%, THD <20%. Luminaire comes with built in 6kV surge protection, which meets a minimum Category C low exposure (per ANSI/IEEE C62.41.2). Fixture ships standard with 0-10v dimmable driver.

INSTALLATION

A universal mounting plate with integral mounting support arms allows the fixture to hinge down for easy access while making wiring connections. The 3/8" Architectural Wall Spacer (AWS) can be used to create a floating appearance or to accommodate small imperfections in the wall surface. The ICW option can be used to mount the luminaire inverted for indirect lighting in dry and damp locations. Design can withstand up to a 1.5 vibration load rating per ANSI C136.31.

LISTINGS

CSA certified to U.S. and Canadian standards. Luminaire is IP66 rated. PIR options are rated for wet location. Rated for -40°C minimum ambient. DesignLights Consortium® (DLC) Premium qualified product and DLC qualified product. Not all versions of this product may be DLC Premium qualified or DLC qualified. Please check the DLC Qualified Products List at www.designlights.org/QPL to confirm which versions are qualified. International Dark-Sky Association (IDA) Fixture Seal of Approval (FSA) is available for all products on this page utilizing 2700K and 3000K color temperature only and SRM mounting only.

BUY AMERICAN ACT

Product with the BAA option is assembled in the USA and meets the Buy America(n) government procurement requirements under FAR, DFARS and DOT regulations. Please refer to www.acuitybrands.com/buy-american for additional information.

WARRANTY

5-year limited warranty. This is the only warranty provided and no other statements in this specification sheet create any warranty of any kind. All other express and implied warranties are disclaimed. Complete warranty terms located at: www.acuitybrands.com/support/warranty/terms-and-conditions

Note: Actual performance may differ as a result of end-user environment and application. All values are design or typical values, measured under laboratory conditions at 25 °C. Specifications subject to change without notice.





WPX LED Wall Packs



Specifications

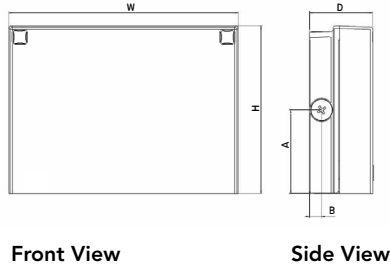

Luminaire	Height (H)	Width (W)	Depth (D)	Side Conduit Location		Weight
				A	B	
WPX1	8.1" (20.6 cm)	11.1" (28.3 cm)	3.2" (8.1 cm)	4.0" (10.3 cm)	0.6" (1.6 cm)	6.1 lbs (2.8kg)
WPX2	9.1" (23.1 cm)	12.3" (31.1 cm)	4.1" (10.5 cm)	4.5" (11.5 cm)	0.7" (1.7 cm)	8.2 lbs (3.7kg)
WPX3	9.5" (24.1 cm)	13.0" (33.0 cm)	5.5" (13.7 cm)	4.7" (12.0 cm)	0.7" (1.7 cm)	11.0 lbs (5.0kg)

Catalog
Number

Notes

Type

Hit the Tab key or mouse over the page to see all interactive elements.

Introduction

The WPX LED wall packs are energy-efficient, cost effective, and aesthetically appealing solutions for both HID wall pack replacement and new construction opportunities. Available in three sizes the WPX family delivers 1,550 to 9,200 lumens with a wide, uniform distribution.

The WPX full cut-off solutions fully cover the footprint of the HID glass wall packs that they replace, providing a neat installation and an upgraded appearance. Reliable IP66 construction and excellent LED lumen maintenance ensure a long service life. Photocell and emergency egress battery options make WPX ideal for every wall mounted lighting application.

Ordering Information

EXAMPLE: WPX2 LED 40K MVOLT DDBXI

Series	Color Temperature	Voltage	Options	Finish
WPX1 LED P1	1,550 Lumens, 11W ¹	30K 3000K	MVOLT 120V - 277V	(blank) None
WPX1 LED P2	2,900 Lumens, 24W	40K 4000K	347 347V ³	E4WH Emergency battery backup, CEC compliant (4W, 0°C min) ²
WPX2 LED	6,000 Lumens, 47W	50K 5000K	E14WC Emergency battery backup, CEC compliant (14W, -20°C min) ²	DBLXD Black
WPX3 LED	9,200 Lumens, 69W		PE Photocell ³	DDBXD Dark bronze DWHXD White Note : For other options, consult factory.

Note: The lumen output and input power shown in the ordering tree are average representations of all configuration options. Specific values are available on request.

NOTES

- All WPX wall packs come with 6kV surge protection standard, except WPX1 LED P1 package which comes with 2.5kV surge protection standard. Add SPD6KV option to get WPX1 LED P1 with 6kV surge protection. Sample nomenclature: WPX1 LED P1 40K MVOLT SPD6KV DDBXD
- Battery pack options only available on WPX1 and WPX2.
- Battery pack options not available with 347V and PE options.

FEATURES & SPECIFICATIONS

INTENDED USE

The WPX LED wall packs are designed to provide a cost-effective, energy-efficient solution for the one-for-one replacement of existing HID wall packs. The WPX1, WPX2 and WPX3 are ideal for replacing up to 150W, 250W, and 400W HID luminaires respectively. WPX luminaires deliver a uniform, wide distribution. WPX is rated for -40°C to 40°C.

CONSTRUCTION

WPX feature a die-cast aluminum main body with optimal thermal management that both enhances LED efficacy and extends component life. The luminaires are IP66 rated, and sealed against moisture or environmental contaminants.

ELECTRICAL

Light engine(s) configurations consist of high-efficacy LEDs and LED lumen maintenance of L90/100,000 hours. Color temperature (CCT) options of 3000K, 4000K and 5000K with minimum CRI of 70. Electronic drivers ensure system power factor >90% and THD <20%. All luminaires have 6kV surge protection (Note: WPX1 LED P1 package comes with a standard surge protection rating of 2.5kV. It can be ordered with an optional 6kV surge protection). All photocell (PE) operate on MVOLT (120V - 277V) input.

Note: The standard WPX LED wall pack luminaires come with field-adjustable drive current feature. This feature allows tuning the output current of the LED drivers to adjust the lumen output (to dim the luminaire).

INSTALLATION

WPX can be mounted directly over a standard electrical junction box. Three 1/2 inch conduit port on three sides allow for surface conduit wiring. A port on the back surface allows poke-through conduit wiring on surfaces that don't have an electrical junction box. Wiring can be made in the integral wiring compartment in all cases. WPX is only recommended for installations with LEDs facing downwards.

LISTINGS

CSA Certified to meet U.S. and Canadian standards. Suitable for wet locations. IP66 Rated. DesignLights Consortium® (DLC) qualified product. Not all versions of this product may be DLC qualified. Please check the DLC Qualified Products List at www.designlights.org/QPL to confirm which versions are qualified. International Dark Sky Association (IDA) Fixture Seal of Approval (FSA) is available for all products on this page utilizing 3000K color temperature only.

WARRANTY

5-year limited warranty. This is the only warranty provided and no other statements in this specification sheet create any warranty of any kind. All other express and implied warranties are disclaimed. Complete warranty terms located at: www.acuitybrands.com/CustomerResources/Terms_and_conditions.aspx.

Note: Actual performance may differ as a result of end-user environment and application. All values are design or typical values, measured under laboratory conditions at 25°C. Specifications subject to change without notice.



One Lithonia Way • Conyers, Georgia 30012 • Phone: 1-800-705-SERV (7378) • www.lithonia.com
© 2020-2022 Acuity Brands Lighting, Inc. All rights reserved.

WPX LED
Rev. 03/08/22

Packet Pg. 48

Performance Data

Electrical Load

Luminaire	Input Power (W)	120V	208V	240V	277V	347V
WPX1 LED P1	11W	0.09	0.05	0.05	0.04	0.03
WPX1 LED P2	24W	0.20	0.12	0.10	0.09	0.07
WPX2	47W	0.39	0.23	0.20	0.17	0.14
WPX3	69W	0.58	0.33	0.29	0.25	0.20

Projected LED Lumen Maintenance

Data references the extrapolated performance projections in a 25°C ambient, based on 6,000 hours of LED testing (tested per IESNA LM-80-08 and projected per IESNA TM-21-11).

To calculate LLF, use the lumen maintenance factor that corresponds to the desired number of operating hours below. For other lumen maintenance values, contact factory.

Operating Hours	50,000	75,000	100,000
Lumen Maintenance Factor	>0.94	>0.92	>0.90

Lumen Output

Luminaire	Color Temperature	Lumen Output
WPX1 LED P1	3000K	1,537
	4000K	1,568
	5000K	1,602
WPX1 LED P2	3000K	2,748
	4000K	2,912
	5000K	2,954
WPX2	3000K	5,719
	4000K	5,896
	5000K	6,201
WPX3	3000K	8,984
	4000K	9,269
	5000K	9,393

Lumen Ambient Temperature (LAT) Multipliers

Use these factors to determine relative lumen output for average ambient temperatures from 0-50°C (32-122°F).

Ambient	Ambient	Lumen Multiplier
0°C	32°F	1.05
5°C	41°F	1.04
10°C	50°F	1.03
15°C	59°F	1.02
20°C	68°F	1.01
25°C	77°F	1.00
30°C	86°F	0.99
35°C	95°F	0.98
40°C	104°F	0.97

HID Replacement Guide

Luminaire	Equivalent HID Lamp	WPX Input Power
WPX1 LED P1	100W	11W
WPX1 LED P2	150W	24W
WPX2	250W	47W
WPX3	400W	69W

Emergency Egress Battery Packs

The emergency battery backup is integral to the luminaire — no external housing or back box is required. The emergency battery will power the luminaire for a minimum duration of 90 minutes and deliver minimum initial output of 550 lumens. Both battery pack options are CEC compliant.

Battery Type	Minimum Temperature Rating	Power (Watts)	Controls Option	Ordering Example
Standard	0°C	4W	E4WH	WPX2 LED 40K MVOLT E4WH DDBXD
Cold Weather	-20°C	14W	E14WC	WPX2 LED 40K MVOLT E14WC DDBXD

Photometric Diagrams

To see complete photometric reports or download .ies files for this product, visit the Lithonia Lighting [WPX LED](#) homepage. Tested in accordance with IESNA LM-79 and LM-80 standards

LEGEND

- 0.1 fc
- 0.2 fc
- 0.5 fc
- 1.0 fc

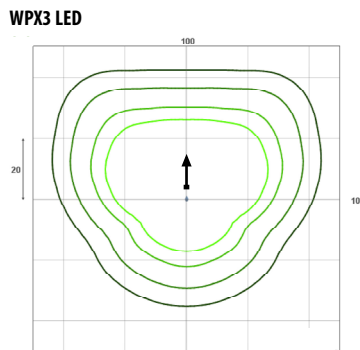
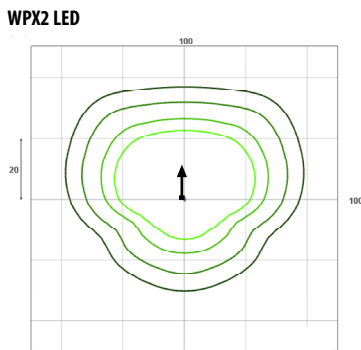
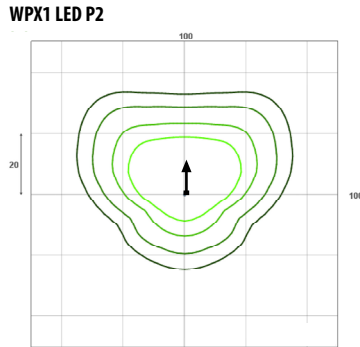
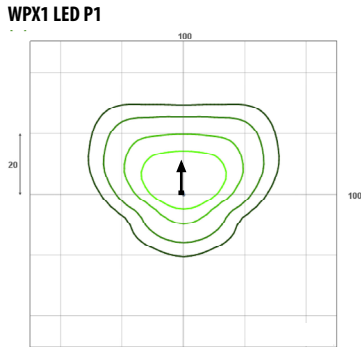

Mounting Height = 12 Feet.



Town of Haymarket
 15000 Washington Street, #100
 Haymarket, VA 20169
 703-753-2600

Thomas Britt
Town Planner

MEMORANDUM

TO: Architectural Review Board
 FROM: Thomas Britt, Town Planner
 DATE: July 19, 2023
 SUBJECT: ARB Review and Historic District Guidelines

Background:

The Haymarket Architectural Review Board currently uses guidelines adopted by the Town Council in September 2010. Town staff have discussed updating the guidelines to better reflect the needs of the Town residents and businesses. Town staff also discussed reviewing the language in the zoning ordinance regarding the historic district in Haymarket.

This discussion of the guidelines can be held in a special meeting prior to the August 16th ARB meeting.

Staff Recommendation: The Town Planner recommends the ARB hold a special meeting August 16th at 6pm to discuss revision of the ARB guidelines, or another proposed date.

Attachment: 01 Historic District Discussion Memo (6237 : ARB Guidelines Work Session)

ARTICLE XVI. - OLD AND HISTORIC HAYMARKET DISTRICT OVERLAY

Sec. 58-16.1 - Definitions.

The following words, terms, and phrases, when used in this article, shall have the meanings ascribed to them in this section, except where the context clearly indicates a different meaning:

'Board' means the Architectural Review Board, abbreviated 'ARB'.

'Altered' means any readily apparent change, including paint.

Sec. 58-16.2 - Purpose and Intent.

The Town of Haymarket seeks to identify, preserve, and enhance landmarks, buildings, structures, and neighborhoods with historical, cultural, and architectural significance to the Town. The historic overlay is intended to implement these goals and ensure that new development is in keeping with the character of Haymarket. The overlay intends to encourage a compatible aesthetic treatment within the Town, promote tourism and visitor opportunities, provide an attractive entry into town, and promote and advance the health, welfare and safety of town residents and visitors.

Sec. 58-16.3 - Creation; boundaries.

- (a) In order to preserve the unique culture of the Town, there is hereby established an overlay district to be known as the "Historic Haymarket Overlay" which shall include all that area that lies within the corporate limits of the Town.
- (b) Prior to any expansion of the historic district the Town shall identify and inventory all structures being considered for inclusion in such a district and shall establish written criteria to be used in making such determination. The Town shall identify all landmarks and designate by ordinance any resource as part of a local historic district, subsequent to soliciting public input in a manner consistent with Code of Virginia, § 15.2-2204. The owners of such property proposed for designation shall be given written notice of the public hearing on the ordinance.
- (c) The town may annually consider updates to the boundaries of the Historic Haymarket Overlay so that it is expanded to include newly identified historic resources, and/or contracted to reflect the removal or demolition of historic resources.

In order to promote the general welfare, through the preservation and protection of historic places and areas of historic interest, all buildings within the Historic Haymarket Overlay which were built prior to 1950 are designated historic resources.

Sec. 58-16.4 - Certificate of appropriateness required in the Historic Haymarket Overlay

- (a) Application for a certificate of appropriateness shall be made to the Architectural Review Board. Any decision of the Architectural Review Board shall be appealable by any member of the Town Council after consultation with the Board, or any aggrieved person to the Town Council.
- (b) No building, structure or sign shall be erected, reconstructed, altered, or restored within the Historic Haymarket Overlay, unless and until a complete application for a certificate of appropriateness shall have been approved by the Board or, on appeal, by the Town Council. Review of such applications by the Board will include analysis of external architectural features which are subject to public view from a public street, way, or place, in light of their architectural compatibility with the historic buildings in the district.
- (c) The zoning administrator shall determine whether a change is readily apparent, subject to appeal to the Board of Zoning Appeals.

Sec. 58-16.5 - Architectural review board; creation, membership.

- (a) For the purpose of making effective the provisions of this article, an Architectural Review Board (ARB) is established. The Board shall consist of up to seven members, but not fewer than five, appointed by the Town Council, and shall be legal residents of the Town. Board members will be appointed from the Town Council

and one from the Planning Commission. Members should have a demonstrated interest, competence, or knowledge of historic preservation.

- (b) The term of office of the members shall be for three years, except that the term of the Council member and Planning Commission member shall correspond to their official tenure of office. Members may be removed from office by Town Council at will and without notice. Appointments to fill vacancies shall be only for the unexpired portion of the term. Members may be reappointed to succeed themselves.

Sec. 58-16.6 - Chairman, vice-chairman, and secretary of the board.

The Architectural Review Board shall elect its chairman and vice-chairman from its membership, and the Town Clerk shall be its secretary.

Sec. 58-16.7- Rules

1. The ARB shall meet for a regular session at least once a month.
2. The Architectural Review Board shall adopt and maintain bylaws governing the procedure for meeting dates and other rules set forth by this article. The bylaws may be reviewed annually for updates.
3. Special meetings may be called in accordance with the ARB procedures as adopted and amended.
4. A quorum shall be no less than a majority of sitting members.
5. All meetings shall be open to the public unless the ARB enters closed session as permitted by the Virginia Freedom of Information Act.

Sec. 58-16.8 - Matters to be considered by the Board

1. The board shall not consider interior arrangement, relative size of the building or structure, detailed design or features not subject to any public view and shall not make any requirements regarding such matters. After receiving a certificate of appropriateness, the zoning administrator shall determine whether this provision applies.
2. The board shall consider the following in passing upon the appropriateness of architectural features:
 - (1) Exterior architectural features, including all signs, which are subject to public view from a public street, way, or place
 - (2) General design arrangement.
 - (3) Texture, material, and color.
 - (4) The relation of the factors, subsections (1), (2), and (3) of this section, to similar features of the buildings and structures in the immediate surroundings.
 - (5) The extent to which the building or structure would be harmonious with or obviously incongruous with the old and historic aspect of the surroundings.
 - (6) In the case of a building to be razed, a primary consideration will be the extent to which its continued existence would tend to protect irreplaceable historic places and preserve the general historic atmosphere of the Town.
 - (7) The extent to which the building or structure will promote the general welfare of the Town, and all citizens, by the preservation and protection of historic places and areas.
 - (8) The extent to which the building or structure will promote the general welfare by:
 - a. Maintaining and increasing real estate value
 - b. Generating business;
 - c. Attracting tourists and visitors;
 - d. Encouraging study of and interest in American history, architecture, and design;
 - e. Making the Town a more attractive and desirable place in which to live.

Sec. 58-16.9 - Issuance of certificate of appropriateness.

Decisions of the Board will be incorporated in approved certificates of appropriateness or written reasons for disapproval. Immediately upon approval by the board of any application to erect, reconstruct, alter, restore, or

raze a building, a certificate of appropriateness, signed by the chairman of the Board and bearing the date of issuance, shall be made available to the applicant. The zoning administrator shall refuse to honor any request for a building permit without such certificate of appropriateness, but a certificate of appropriateness will in no way affect the requirement to comply with the other provisions necessary to obtain a building permit.

Sec. 58-16.10 - Right of appeal.

- (a) Whenever the board shall approve or disapprove an application for a certificate of appropriateness or fail to take action within 60 days of its filing, any aggrieved party shall have the right to appeal and be heard before the Town Council provided such person files with the Town Clerk on or before 30 days after the decision of the board a written notice of appeal. Upon receipt of such notice, the Town Clerk shall place such appeal on the agenda for the next regular meeting of the Town Council.
- (b) Any party may appeal the decision of the Town Council to the circuit court pursuant to this section.
 - (1) A party is any applicant or any person who owns property adjacent to the property which the application concerns. For the purposes of this section, the term "adjacent" includes any property separated from the applicant's property only by a road and which would be adjacent if the road were not present.
 - (2) Appeal shall be by petition at law setting forth the alleged illegality of the action of the Town Council.
 - (3) The appellant must file the appeal with the circuit court of the county within 30 days of the Town Council's decision.
- (c) In addition to the right of appeal, the owner of an historic landmark, building or structure shall have a right to raze or demolish such landmark, building or structure provided he has complied with the provisions of the second paragraph of Code of Virginia, § 15.2-2306(A)(3), as amended.

Sec. 58-16.11 - Deterioration by neglect.

- (a) No owner of an officially designated historic building within the historic district shall allow it to deteriorate to the point where it is not economically feasible to repair or restore it. Specifically, no owner may permit:
 - (1) Deterioration of the exterior of a historic building to the extent that it creates or permits a hazardous or unsafe condition;
 - (2) Deterioration of exterior walls or other vertical supports, horizontal members, roofs, chimneys, exterior wall elements such as siding, wooden walls, brick, plaster, or mortar, of a historic building to the extent that it adversely affects the character of the historic district or could reasonably lead to irreversible damage to the structure. In determining whether deterioration adversely affects the character of the historic district, the zoning administrator shall be guided by the comprehensive plan and, if adopted, the strategic plan and capital improvements budget.
- (b) If a building inspector determines that a historic structure is violating the Property Maintenance Code, he shall so notify the owner, the zoning administrator, and the chairman of the Architectural Review Board of this conclusion, stating the reason for such determination, and shall give the owner 30 days from the date of the notice in which to commence work rectifying the specifics, or to initiate a request to demolish, move or relocate such structure. If appropriate action is not timely taken, the Town Building Inspector shall initiate appropriate legal action.

Sec. 58-16.12 - Demolition review and approval

1. No historic resource, as defined in this article within the Historic Haymarket Overlay shall be demolished or moved, in whole or in part, until the demolition or moving thereof is approved by the Architectural Review Board, or, on appeal by the town council after consultation with the ARB.
2. In addition to the right of appeal set forth herein, the owner of a historic resource, the demolition or moving of which is subject to the provisions of this section, shall, as a matter of right, be entitled to demolish or move such historic resource provided that:

- a. The owner or applicant has applied to the town council for such right,
 - b. the owner has for the period of time set forth in the schedule contained in Section 15.2-2306 of the Virginia code and at a price reasonably related to its fair market value, made a bona fide offer to sell the historic resource, and the land pertaining thereto, to the town or to any person, firm, corporation, government or agency thereof, or political subdivision or agency thereof, which gives reasonable assurance that it is willing to preserve and restore the historic resource and the land pertaining thereto, and,
 - c. No bona fide contract, binding upon all parties thereto, shall have been executed for the sale of any such historic resource, and the land pertaining thereto, prior to the expiration of the applicable time period set forth in the time schedule specified in the Virginia Code. Any appeal which may be taken to the court for the decision of the town council, whether instituted by the owner or by any other proper party, notwithstanding the provisions heretofore stated relating to a stay of the decision appealed from shall not affect the right of the owner to make the bona fide offer to sell referred to above. No offer to sell shall be made more than one year after a final decision by the town council, but thereafter the owner may renew his request to the town council to approve the demolition or moving of the historic resource.
3. Demolition Approval Criteria Considerations. In reviewing applications for the demolition or moving of a historic resource from or within the Historic Haymarket Overlay, the Architectural Review Board shall consider the following:
- a. How the demolition or removal of a historic resource from the property on which it is located will impact the historic integrity of the site and any remaining on-site historic resources on the same property;
 - b. How the loss of the historic resource will impact the historic integrity of any adjacent historic property;
 - c. The impact the loss of the historic resource will have on the overall integrity to any historic district the historic resource is located in ;
 - d. The ability of the historic resource to be adaptively reused as part of a new on-site development which would not adversely impact the historic resource's ability to convey its historic significance through its integrity of location, setting, feeling, association, design, materials and workmanship; and
 - e. Whether any monies or assistance for preservation of the historic resource could be made available to the property owner within 180 days of the owner's request to demolish or move it.

Sec. 58-16.13 Time Limit

A certificate of appropriateness shall be valid for one (1) year from the date of issuance. If the demolition, erection, reconstruction, alteration, relocation or restoration for which the certificate of appropriateness was issues is not commenced within one year and thereafter diligently pursued, a new certificate shall be obtained prior thereto.



County of Prince William

**HISTORIC DISTRICT
DESIGN GUIDELINES**

FOR

THE ARCHITECTURAL REVIEW BOARD

**Adopted by the Town Council September 7, 2010
Public Hearing Held June 22, 2010**

Adopted by the Haymarket Town Council by a quorum present, upon a roll call vote, as follows:

Motion By: Edwards
 Seconded By: Scarbrough
 Voting Aye: Edwards, Cole, Scarbrough, Kenworthy, Weir
 Voting Nay: Tobias
 Absent: 0
 Abstain: 0

Done this 7th Day of September 2010

ATTEST:

 Pamela E. Stutz, Mayor

 Clerk

Table of Contents

I. INTRODUCTION.....	4
A. BACKGROUND AND PURPOSE OF THE DESIGN GUIDELINES	4
B. APPROVAL BY ARB MAY BE ONLY ONE STEP IN REQUIRED APPROVAL PROCESS	5
C. CERTIFICATE OF APPROPRIATENESS	5
D. EXEMPTIONS	6
E. COMMUNITY DESIGN AND THE COMPREHENSIVE PLAN	6
II. STREETScape AND SITE DESIGN GUIDELINES	8
A. WASHINGTON STREET ENHANCEMENT PROJECT	8
B. STREETScapeS OTHER THAN WASHINGTON STREET	8
C. FENCES AND WALLS.....	8
D. LIGHTING (FREE STANDING/POSTS).....	10
E. TELECOMMUNICATION DISHES, DRUMS AND TOWERS.....	10
F. SCREENING.....	11
III. NEW CONSTRUCTION AND ADDITIONS TO EXISTING NON-HISTORIC AND NON- CONTRIBUTING STRUCTURES.....	11
A. GENERAL GUIDELINES	11
B. COLORS	11
C. EXTERIOR ELEMENTS	11
D. CHIMNEYS.....	12
E. ROOFING	12
F. LIGHTING (ATTACHED TO STRUCTURE).....	12
G. WINDOWS AND DOORS.....	13
H. DECKS	13
I. HANDICAPPED RAMPS	13
J. AWNINGS	13

IV. GUIDELINES FOR ALTERATIONS OR ADDITIONS TO HISTORIC STRUCTURES OR CONTRIBUTING STRUCTURES..... 14

 A. GENERAL GUIDELINES 14

V. SIGNAGE..... 14

VI. DEMOLITION..... 15

 A. SPECIAL INSTRUCTIONS FOR HISTORIC STRUCTURES 15

VII. SITUATIONS NOT COVERED, ADDITIONAL REQUIREMENTS..... 15

VIII. LEGAL STATUS OF GUIDELINES 16

APPENDIX A: APPROVED FONTS..... 17

APPENDIX B: SIGN DESIGN EXAMPLES..... 19

APPENDIX C: FENCE STYLES 22

APPENDIX D: LIST OF HISTORIC STRUCTURES 25

APPENDIX E: PAINTING OF HISTORIC STRUCTURES 26

APPENDIX F: ZONING MAP 32

I. INTRODUCTION

A. BACKGROUND AND PURPOSE OF THE ARCHITECTURAL REVIEW BOARD AND THE DESIGN GUIDELINES

In 1994 the Haymarket Town Council (herein after, the “Town Council”) placed the entire town under a Historic District Zoning Ordinance. A “Historic District” is an overlay zoning which imparts additional protection specific to historic structures and the historic resources of the Town in addition to underlying zoning requirements already required by a locality’s zoning regulations. The adoption of a local historic district and ordinances to protect historic resources is authorized by Sec. 15.2.2306, et. Seq, of the Virginia Code, which recognizes the importance of preserving a local jurisdiction’s historic heritage. A local property does not have to be listed in either a state or national register in order to be designated historic on the local level. The Town Code designates “historic” as all structures that are 50 years old or older.

See Appendix D for a list of the Town’s Historic Structures

When the Town Council adopted the Historic District in 1994 it also established the Haymarket Architectural Review Board (herein after, the “ARB”) and determined that no building, structure or sign shall be erected, constructed, or altered until the ARB has issued a Certificate of Appropriateness (COA). The regulations imposed in the district are intended to protect against the destruction of, or encroachment upon, Haymarket’s historic structures and resources.

Any change within the Historic Overlay District including, but not limited to:

- rehabilitation of or additions to existing buildings
- new construction
- razing or demolition

must be reviewed and approved by the ARB before a COA may be granted.

Any change undertaken without issuance of a COA may, among other actions, be ordered removed and returned to the original condition.

The following has been adopted by the Town Council to provide the ARB with guidelines to follow during their review procedure. Modifications to these guidelines may be suggested by the ARB at any time, but all modifications must be reviewed and approved by the Town Council prior to implementation.

It is the intent of the Town of Haymarket (herein after, the “Town”), by adoption of these guidelines, to maintain and promote the historic resources and appropriate architectural styles within the Town.

It is not the intent of the Town to restrict or prevent homeowners from remodeling, adding to, or otherwise enhancing their property. However, the ARB will interpret what will be considered the unique characteristics of the Town’s historic structures

and may refer to architectural and historic sources other than these guidelines in order to make recommendations about all design issues not expressly defined in these guidelines.

In accordance with the Town of Haymarket Historic Overlay District Ordinance, these guidelines are to be applied to those improvements which currently or in the future could be visible from any public view.

The ARB is guided by the Code of the Town of Haymarket, the laws of the Commonwealth of Virginia, and the Town of Haymarket Comprehensive Plan.

B. APPROVAL BY THE ARB MAY BE ONLY ONE STEP IN REQUIRED APPROVAL PROCESS

The regulations imposed by the Historic District Zoning Ordinance are in addition to the requirements of the Town Code, state and federal laws and building codes. Therefore, application to and approval by the ARB may only be one step in the process of receiving full approval of an application. It is the responsibility of all applicants to comply with all building codes and state, federal, and Town requirements.

C. CERTIFICATE OF APPROPRIATENESS

The Certificate of Appropriateness (COA) is the vehicle by which an applicant receives approval for an application before the ARB. The COA expires one (1) year after the date of approval by the ARB if the new construction and/or changes to an existing structure described in the application have not been completed.

1. Procedure

- Application for a Certificate of Appropriateness (COA) shall be filed with the Town Clerk with all required accompanying documentation and fees.
- The board shall meet within 45 days after notification by the Town Clerk that such application is complete and ready for consideration.
- The applicant, or a representative, is required to attend the meeting at which their application is to be heard. If the applicant or the applicant's designee does not appear before the board, the application may be deferred until the next meeting. If this applicant or their representative does not again appear, the application may be discontinued.
- The board shall endeavor to vote and announce its decision on any matter properly presented within 14 days after the conclusion of the final hearing on the matter unless time is extended by mutual agreement between the board and the applicant or the circumstances or complexity of the application require a longer period.
- The board shall not reconsider any decision made by it except in cases where an applicant appears with an amended application addressing all areas of concern and two-thirds of a quorum of the Board votes to reconsider such applications.

2. Appeals

- Whenever the board shall approve or disapprove an application for a COA, any aggrieved party or member of the Town Council shall have the right to appeal and be heard before the Town Council provided such person files a written notice of intention to appeal with the Town Clerk on or before 14 days after the decision of the board.
- Upon receipt of such notice, the Town Clerk shall place such appeal on the agenda for the next regular meeting of the Town Council, at a time not to exceed 45 days after the receipt of such notice of appeal.

D. EXEMPTIONS

When in compliance with all Town ordinances and other requirements, the following projects are exempted from all provisions of these Design Guidelines:

- Routine maintenance work on buildings that does not significantly alter the appearance or function of the building, nor materially replaces old roofing, siding, or window materials with new materials substantially identical to the repaired materials. Replacement of more than 10% of a feature (i.e. roof, siding, etc.) is NOT considered routine maintenance and shall be deemed “material”.
- Interior remodeling work.

E. COMMUNITY DESIGN AND THE COMPREHENSIVE PLAN

According to the Town’s Comprehensive Plan (2008-2013), a close relationship between the Planning Commission (PC) and the Architectural Review Board (ARB) is necessary to implement a community design. The PC is responsible for ensuring that development plans abide by existing land use and zoning ordinances whereas the ARB is responsible for ensuring that the design of new structures and the modification of existing buildings adhere to an overall architecture consistent with the Historic District Ordinance and these Guidelines. The community design plan must be a balance of meeting future and current community needs, saving and rehabilitating historic structures, and allowing homeowners and business owners enough latitude to enhance their properties all while creating and preserving the historic “character” of Haymarket.

This plan can be described with respect to the main geographic portions of the town:

Industrial/Retail, West of Fayette Street

As development has progressed, styles of new buildings show a regression of architectural styles from modern (Sheetz), to neo-colonial (Leaberry and Quarles shopping centers), to late-1800s urban (Bloom building) and finally to colonial (Giuseppe’s Restaurant and Remax Realtors). One historic structure has been saved, Winterham, albeit in the midst of a new shopping and professional complex. This regression is in concert with the overall goal of maintaining the feel of the town center as the oldest portion of Haymarket. Only one property of this part of town is

undeveloped, the land between Quarles and Giuseppe's Restaurant. The overall design of a retail or professional complex on this site must flow into this age progression. Accordingly, the style and size of structures here should be consistent with mid-1800 and early 1900 historic architecture. Locations in this part of town should be accessible by foot traffic. Parking will generally be available on site and is to be behind the structure, if feasible.

Historic/Walking/Central Portion of Town

This portion of Haymarket houses the old Town Hall, now the Haymarket museum, and the historic old post office. Development here should be carefully considered and should reflect the architecture that lines Washington Street and defines historic Haymarket. Architectural styles and building sizes should include Colonial, Federalist, and Folk Victorian with Greek revival and Italianate architectural details. Visual interest should be encouraged through the use of height variations ranging from one to three stories. Retail and professional buildings should be arranged in a "walk-around" manner, with parking off-site. In essence, development in this area should create a town center with a historical feel in which residents and visitors can walk, shop, eat, conduct business and relax. Restoration of the old post office will be required as part of any development plan. Consideration must be made to the utility of maintaining town hall in this portion of town or moving it to another location. From this point in town, all other structures should begin to look "newer".

Commercial/Residential Blend East of Town's Center

Traveling east from the central portion of town, Haymarket unfolds in a pleasant mix of older, residential homes and low intensity commercial uses such as a veterinary clinic and a Baptist Church. This blend of uses continues to the eastern town limit, where a neo-colonial residential development is across the street from public uses in two Sears houses fronted by a planned village green. The two Sears structures fit this area architecturally and historically and should be preserved, if at all possible. Almost all the land north and south of Washington Street is developed. Much of the available land on the north side of Washington Street seems well suited to low intensity commercial uses, with adequate buffering to separate it from residential neighborhoods. Whenever possible, existing residential buildings should be converted to commercial use, rather than have new buildings constructed, to continue the open, small town atmosphere and sense of place. As per the ARB guidelines, any new development must follow architectural styles represented by the surviving historic buildings in Haymarket. In general, developments within the last seven years have been styled as neocolonial. As other residential developments are planned, the ARB will encourage developers to move away from "cookie cutter" designs and explore styles that reflect a post-Civil War era. This would include Victorian styles. Modern or industrial designs are not consistent with the Historic District and are not appropriate.

Overall Plan

The overall community design and its resulting policies should produce a Haymarket that gives the impression of "built over time". Each of these sections of town discussed above should flow into the other. As developers present designs and

requests for zoning changes, the PC, ARB, and, ultimately, the Town Council must keep this overall design goal in mind when approving these designs and granting requests.

II. STREETSCAPE AND SITE DESIGN

These applications require additional approval from the Town Council and Planning Commission

A. WASHINGTON STREET ENHANCEMENT PROJECT

There are additional Town Code requirements for the Washington Street area.

- The Washington Street Enhancement Project encompasses the improvement of Washington Street throughout the Town limits and includes enhanced pedestrian, bicycle, and vehicle access through the Town.
- The project also includes installation of brick sidewalks, colonial-style streetlights, park benches, trash receptacles, bicycle lanes and racks, brick planters and requisite engineering.

B. STREETSCAPES OTHER THAN WASHINGTON STREET

- Benches, trees, trash receptacles, and streetlights may not be placed on public rights-of-way unless considered appropriate by the ARB and with approval of the Town Council.
- At no time may sidewalks be constructed of material other than concrete or brick.
- The style and color of the sidewalk shall be consistent in material and pattern throughout the length of the street.
- For the selection of patterns and materials for sidewalks, the ARB will make reasonable effort to supply a list of approved material and patterns, and this information shall be made available for review at the Town Hall.

C. FENCES AND WALLS

*These applications require additional approval by the Planning Commission
See Appendix C for Fence Style Examples*

The Town Code provides for additional requirements for fences within the Town and must be reviewed by the applicant as part of the application procedure.

1. Types

- Wood or wood-look products in the style of a picket, board, or split-rail.
- Wrought iron.
- Other fence styles, such as ornamental and privacy fences will be considered on a case-by-case basis.

- Screen fencing is discussed in Section II H.
- At no time will stockade, snow fencing, exposed chain link fencing or barbed or razor wire (or any similar exposed security fencing) be allowed within the Town.
- Alternating board fences are not approved for new fences. Those alternating board fences constructed prior to the adoption of these guidelines may be maintained within the Town provided that no more than twenty-five percent of the fence is replaced.

Notwithstanding the foregoing, all existing residential lots located within the subdivision commonly known as Longstreet Commons, are hereby exempted from the prohibition of board on board fences based on the following findings by Council:

1. All of these lots are subject to a restrictive covenant that any fence constructed must be board on board and none other.
2. This subdivision was created in the year 1987.
3. Since that time and prior to the adoption of these Guidelines, approximately 110 lots have constructed board on board fences in conformity with the requirements of the covenants.
4. Due to the foregoing circumstances, unique to these lots, Longstreet Subdivision should be exempted from the requirements of the Guidelines.

2. Materials

Colors and choice of materials for fences and walls shall compliment and be consistent with the design and materials of the parent building.

3. Special Instructions

- For picket fencing, pickets must be separated from each other by a space of one to three inches but should not be any wider than the width of the picket. Additionally, the picket will have a horizontal width of two to four and one-half inches. The fence will be constructed with the finished side facing outside of the fenced property.
- Board fencing will be constructed of six-inch wide boards. If more than twenty-five percent is to be replaced, then the entire fence will be considered as a new fence and must adhere to these guidelines.
- For split-rail fencing, a maximum of three rails is permitted. The height of a split-rail fence should not exceed 48 inches at the highest rail.
- Partial and/or decorative fencing styles should be appropriate to the architecture of the parent building. Partial and/or decorative fences are not to be used extensively along the property line.
- For fences with an open design, wire mesh can be used to contain pets. The wire mesh should be of a heavy gage in black or dark green with a square or rectangular weave. It should be installed on the inside of the fence and not extend above the top of the fence or top rail in a split-rail design. “Chicken wire” is not approved.

4. Gates

- All fence gates should match the design and construction of the fence.
- If a matching design cannot be met due to structural integrity, a solid board or vertical picket design can be substituted.
- The gate may have either a flat level top or a rounded top.
- Ornamental gates will be considered if the design is harmonious with the parent structure architecture and fence style.
- Gates should be single hung with the stile at the same height as the fence.

5. Heights

- In all zoning districts, the height of any fence shall comply with the Town Code.

6. Walls

- Freestanding walls may only be constructed of brick, concrete or fieldstone. If concrete or concrete block is used, it shall have a façade of brick or fieldstone.
- Retaining walls shall be constructed of brick, concrete, fieldstone or wood. If constructed of wood, a minimum of six-inch by six-inch beams in rectangular cross-section will be used. Pressure treated wood or railroad ties must be used.

D. LIGHTING (FREE STANDING/POSTS)

- All exterior lighting schemes shall be preplanned in its entirety and such plans, with detailed specifications, shall be presented to the ARB for consideration and approval.
- Business Town lighting located along Washington Street shall also be in accordance with the Streetscape Plan.
- Free standing light posts shall be compatible with the prevailing and recognized historic architectural character of the Town.
- Fixtures shall utilize an incandescent lighting source. If a more intense light source is needed, metal halide or an equivalent lighting method shall be used.
- Free standing lights shall not exceed sixteen feet in height in business and industrial zones and
- Free standing lights shall not exceed six feet in height in residential zones.
- All free standing lights shall be directed downward onto the site and light shall not materially project onto adjoining properties.
- A combination of free standing and wall-mounted fixtures is recommended in order to yield varied levels of lighting.

E. TELECOMMUNICATION DISHES, DRUMS AND TOWERS

These applications require additional approval by the Planning Commission and/or Town Council

- Communication dishes or drums located in an Industrial zoned district must be surrounded by fencing and obscured from view if mounted on the ground.

- Any exposed dish or drum mounted on a tower or monopole shall be painted white or another color approved by the ARB.
- No antenna higher than twenty-four linear feet from ground level shall be constructed or attached to any building or structure within the Industrial-zoned district.

F. SCREENING

- All outdoor utilities, transformers, meters, trash dumpsters, mechanical, heating and a/c units shall be screened from the public view by walls, fences, landscaping or a combination thereof. Where landscaping is used, it shall provide a year-round screen and applicants should also refer to the Town Code for landscaping screening requirements.
- If roof-mounted mechanical equipment is used, it shall be screened from public view on all sides. The screening material and design shall be consistent with the design, textures, material, and colors of the building. The screening shall appear as an integral part of the building.

III. NEW CONSTRUCTION AND ADDITIONS TO EXISTING NON-HISTORIC AND NON-CONTRIBUTING STRUCTURES

A. GENERAL GUIDELINES

- The ARB will consider all new construction designs keeping in mind the Town's Community Design plan as put forth in the Comprehensive Plan [see Introduction section E of these guidelines].
- In order to create a more pleasing blend of historic and new elements in the Town, new structures shall be compatible with the prevailing and recognized historic architectural character of the existing adjacent structures.
- New buildings shall be designed to complement rather than detract from adjacent buildings in terms of mass, scale, and materials.

B. COLORS

- Painting shall be done using colors complementary to adjacent structures as well as being appropriate for the adjacent architectural styles.
- Colors of a building shall also take into consideration roof, foundation materials and design elements and principle.
- The approved colors are from the Martin Senour Paints Williamsburg collection. These colors may be viewed at the Town Hall office.
- Corporate logo colors may not meet the Town design guidelines and may not be approved.

C. EXTERIOR ELEMENTS

• Foundations

Foundation exteriors must be comprised of brick, stone or concrete with a brick relief.

- **Siding**

The following materials may be considered acceptable for exteriors of buildings within the Town, if consistent with the other requirements of the Historic District Ordinance and these Guidelines:

1. Wood
2. Wood-look Vinyl Siding, if consistent in quality and texture with Historic District requirements
3. Hardboard Siding
4. Stone
5. Brick

Paneling and exposed cinder or concrete blocks are not appropriate for any structures. The ARB may consider other exterior materials if such material is consistent with the Historic District Ordinance and these Guidelines.

- **Decorative Detailing**

All new construction in the Colonial style shall have exterior dentil moldings where appropriate that must be proportionate to the size and scale of the structure.

D. CHIMNEYS

These applications require additional approval by the Planning Commission and possible the Town Council

- The exteriors of all exposed chimneys or mock-chimneys constructed in the Town shall be constructed of brick, stone, or brick and stone facing.
- The exterior design shall include a connection to the base or ground of the home and extend above the roofline.

E. ROOFING

- Roof design, materials, colors and textures shall be consistent with the Historic District Ordinance and these Guidelines.
- Roof materials may include metal, composition shingle and wood.
- Wherever pressed tin or standing seam style roofs exists, it shall be preserved and refurbished unless the cost of such preservation/refurbishing exceeds twenty-five percent of the assessed value of the structure.
- On any additions to structures with existing pressed tin roofs, the same roof style shall be extended.

F. LIGHTING (ATTACHED TO STRUCTURE)

- Fixtures shall utilize an incandescent lighting source
- Utilitarian fixtures or bare bulbs shall not be permitted in the Town.

G. WINDOWS AND DOORS

- Only full view storm doors and windows are permitted.
- Sliding glass doors shall not be allowed on the front of the structure if they are visible from a public way or street.

H. DECKS

These applications require additional approval by the Planning Commission:

- Deck plans must be submitted to the ARB for design approval with a list of materials.
- Potential materials are:
 1. Pressure-treated lumber
 2. Manufactured wood
 3. Composite material such as TREX[®] or other similar product
 4. Wood
- Deck colors will match either the primary or trim color of the structure.
- Once painted or stained, the finish should be maintained to prevent peeling.

I. HANDICAPPED RAMPS

- Handicapped ramps shall be at the rear or side of a building where possible.
- The ramp shall not be manufactured in a runway style perpendicular to the front façade. However, if it adds undue burden for handicap access, other placement options will be considered.
- Potential materials are:
 1. Pressure-treated lumber
 2. Manufactured wood
 3. Composite material such as TREX or other similar product
 4. Wood

All Handicap Ramps must meet the American Disabilities Act (ADA) requirements.

J. AWNINGS

- Awnings may be permitted if consistent with the Historic District Ordinance and these Guidelines.
- Material used to construct awnings or canopies shall be limited to canvas or similar material.
- Vinyl, plastic or aluminum will not be considered as material for use in the construction of awnings or canopies.
- The design of the awning and color of the cloth should complement the building.
- The scale of the design should be related to the proportions of the building.
- Awnings must be a solid color.
- All awnings should be well maintained, washed regularly, and replaced when faded or torn.

- Any lettering applied to an awning shall be considered a sign and must comply with the Town Ordinance regarding signs.

IV. GUIDELINES FOR ALTERATIONS OR ADDITIONS TO HISTORIC STRUCTURES OR CONTRIBUTING STRUCTURES

The Town Code designates “historic” as all structures that are 50 years old or older.

See Appendix C for a list of the Town’s Historic Structures

A. GENERAL GUIDELINES:

- Any exterior alteration or addition to a historic structure has the potential to radically alter the structure’s appearance and/or obscure its historic significance. When an alteration or addition is planned, it shall be designed and constructed in a manner consistent with the architecture and design elements of the period of initial construction and not detract from the character-defining features of the historic structure. To this end, the ARB shall examine the proposed modifications to the historic structure and determine if such proposed modification would detract from the significance or integrity of the structure.
- The following considerations shall be met in any renovation or addition to a historic structure:
 1. The size and scale of any alteration or addition shall be limited so as not to compromise the integrity of the historic structure or the surrounding structures.
 2. The alteration or addition must use materials, level of detail, fasteners, finishes and colors that are consistent with the historic structure’s period of construction and should take into account compatibility with surrounding structures.
 3. The alteration or addition must incorporate the design elements and principles of the existing structure.
 4. Original siding materials shall be repaired and retained, rather than removed or covered. If replacement must be made, and is approved by the ARB, it must be with like materials. Replacing original wood siding with cement siding products, such as Hardiplank siding, is not permitted.
 5. Existing paint may be removed if done in a manner that will not damage the surface of the structure. Such method of paint removal shall be reviewed in advance by the ARB if such facility is a historic building.

See appendix E for Painting Instructions

V. SIGNAGE

All signs shall be in strict conformance with the Haymarket Town Code and all other applicable requirements.

These applications require additional approval by the Planning Commission and/or Town Council

*See Appendix A for Font Styles
See Appendix B for Sign Examples*

- Signs should make a positive contribution to the general appearance of the street and neighborhood in which they are located as well as complement the architecture of the building(s).
- It is not a given that corporate business logos or color schemes will meet sign guidelines. The ARB strongly encourages the use of durable synthetic materials.

VI. DEMOLITION GUIDELINES

The Town Code has important requirements for all demolition of buildings within the Town.

A. SPECIAL INSTRUCTIONS FOR HISTORIC STRUCTURES

The Haymarket Comprehensive Plan supports the preservation of the Town's historic resources to the greatest extent possible. Therefore, there must be a compelling reason to demolish a historic structure.

- Applicants must provide a written statement explaining the reason for the demolition and describe alternatives to demolition and why such alternatives are not considered feasible.
- In some instances, the ARB may require a structural analysis of the building by a licensed professional engineer regarding the structural integrity of a building prior to a demolition permit decision.
- If an applicant is successful in demonstrating that a historic structure is a candidate for demolition the ARB may approve the demolition request with one or more of the following conditions, depending on the circumstances surrounding the request:
 1. Complete, professional, photographic documentation of the interior and exterior of the building, including black and white print and digital images.
 2. Phase I archaeological survey of the property to determine if the property yields information important to the Town's history.
 3. The applicant must demonstrate that the site will be prepared and maintained in accordance with a landscape plan once the building has been demolished.
 4. The demolition may occur only following receipt of a building permit for the new construction.

VII. SITUATIONS NOT COVERED, ADDITIONAL REQUIREMENTS

These guidelines do not cover every possible situation. Architectural alterations or construction requests not covered by these Guidelines will be reviewed for appropriateness by the ARB on a case by case basis applying the standards and principles

set forth in these Guidelines and the Town's Comprehensive Plan and ordinance provisions. It is the responsibility of all applicants to comply with all Town building, zoning, subdivision and land use requirements as well as all state and federal requirements.

VIII. LEGAL STATUS OF GUIDELINES

The Town Council recognizes it is not possible to define what may or may not be required in the many unique circumstances which will occur in the Historic District. It is therefore impossible to define by ordinance precisely how to apply the Historic District Ordinance to these type situations. These Guidelines are the result of mature consideration by the Town Council after input and comment by the public, the ARB, the Planning Commission and the residents of the Town. These Guidelines shall have the legal force of a town ordinance and shall provide the legal framework for achieving the purposes of the Historic District Ordinance and the preservation of the Town's historic resources in the Historic District. By application of these Guidelines and the Historic District Ordinance, relevant matters will be decided in a consistent fashion. These Guidelines also provide important guidance to property owners within the Historic District.

APPENDIX A: APPROVED FONTS

Font Samples:

Bradley ITC
 ABCDEFGHIJKLMNOPQRSTUVWXYZ
 abcdefghijklmnopqrstuvwxyz
 1234567890

Californian FB
 ABCDEFGHIJKLMNOPQRSTUVWXYZ
 abcdefghijklmnopqrstuvwxyz
 1234567890

Century Schoolbook
 ABCDEFGHIJKLMNOPQRSTUVWXYZ
 abcdefghijklmnopqrstuvwxyz
 1234567890

Garamond
 ABCDEFGHIJKLMNOPQRSTUVWXYZ
 abcdefghijklmnopqrstuvwxyz
 1234567890

Georgia
 ABCDEFGHIJKLMNOPQRSTUVWXYZ
 abcdefghijklmnopqrstuvwxyz
 1234567890

Geoslab
 ABCDEFGHIJKLMNOPQRSTUVWXYZ
 abcdefghijklmnopqrstuvwxyz
 1234567890

Goudy Oldstyle
 ABCDEFGHIJKLMNOPQRSTUVWXYZ
 abcdefghijklmnopqrstuvwxyz
 1234567890

Monotype Corsiva
ABCDEFGHIJKLMNOPQRSTUVWXYZ
abcdefghijklmnopqrstuvwxyz
1234567890

Pegasus
ABCDEFGHIJKLMNOPQRSTUVWXYZ
abcdefghijklmnopqrstuvwxyz
1234567890

Tahoma
ABCDEFGHIJKLMNOPQRSTUVWXYZ
abcdefghijklmnopqrstuvwxyz
1234567890

Times New Roman
ABCDEFGHIJKLMNOPQRSTUVWXYZ
abcdefghijklmnopqrstuvwxyz
1234567890

Tunga
ABCDEFGHIJKLMNOPQRSTUVWXYZ
abcdefghijklmnopqrstuvwxyz
1234567890

APPENDIX B: SIGN DESIGN EXAMPLES

The following examples of current Town Business signs demonstrate the subdued style from 1750 to 1900. They are not inclusive of all acceptable sign styles. Any particular sign style must be approved by the ARB in a certificate of appropriateness.

(Use of these images is for exemplary purpose only and is not an endorsement of any business shown. Letter typestyle can be found in Appendix A)

MENU SIGNS



HANGING SIGNS



Attachment: arb_guidelines_adopted_by_council_09-2010 (6237 : ARB Guidelines Work Session)

FREESTANDING SIGNS



INDIVIDUAL LETTER SIGNS



WALL SIGNS



DIRECTIONAL SIGN



NEON “OPEN” SIGN (Non-Flashing/Non-Moving)



APPENDIX C: APPROVED FENCE STYLES



Attachment: arb_guidelines_adopted_by_council_09-2010 (6237 : ARB Guidelines Work Session)

PICKET STYLE FENCES:



ENCLOSURES:



Attachment: arb_guidelines_adopted_by_council_09-2010 (6237 : ARB Guidelines Work Session)

OTHER FENCE STYLES/RETAINING WALLS:



Ornamental Fencing



Wrought Iron Fence



Stone Retaining Wall



Wood Retaining Wall

Attachment: arb_guidelines_adopted_by_council_09-2010 (6237 : ARB Guidelines Work Session)

APPENDIX D: HISTORIC STRUCTURES

Address	Date of Construction	Historical Name
14710 Washington Street	ca. 1924	Sears House
14740 Washington Street	ca. 1926	Sears House
14801 Washington Street	ca. 1900's	Jordan House
14800 Washington Street	ca. 1900	Baptist Church
14841 Washington Street	ca. 1900	Watts House
14881 Washington Street 14891 Washington Street	ca. 1900 ca. 1900	House LeRoy House/Madison Shop
14910 Washington Street	ca. 1895	Melton House/store
14941 Washington Street 14950 Washington Street	ca. 1948 ca. 1870's Built on site of the Red House Tavern	Old Fire Station (first one in Western Prince William County) Roland House/Red House Tavern (first building built before Haymarket became a town)
14951 Washington Street	ca. 1910	Old Bank Building
15020 Washington Street	ca. 1920's	Old Post Office
15030 Washington Street	ca. 1920	Rust/Pickett House
15101 Washington Street	ca. 1888/90	Dr. Payne House/Winterham
6590 Jefferson Street	ca. 1910	Garrett House
6620 Jefferson Street 6707 Jefferson Street	ca. 1900 ca. 1920's	Downs House Large example bungalow
6706 Jefferson Street	ca. 1901	Gossom House
6712 Jefferson Street	ca. 1935	Baker/Bean House
6713 Jefferson Street	ca. 1910	Masonic Lodge
6720 Jefferson Street 6741 Jefferson Street	ca. 1930 ca. 1890	Gossom House Brownie Smith House
6751 Jefferson Street	ca. 1870	Alrich House
6771 Jefferson Street 6810 Jefferson Street	ca. 1870-80 c. 1900	Wise/Creech House Leonard House
6811 Jefferson Street	ca. 1890	James Beale House
6735 Fayette Street	ca. 1911	St. Paul's Parish Hall
6740 Fayette Street	ca. 1890-1910	Meade House
6750 Fayette Street	ca. 1900	St. Paul's Rectory
6790 Fayette Street 6796 Fayette Street	ca. 1930 ca. 1800	Sarah Turner House Pearson's House

APPENDIX E: PAINTING OF HISTORIC STRUCTURES

Source: *Warrenton Historic District Design Guidelines, Warrenton, VA*
prepared by Cheryl Hanback Shepherd, 2008

www.warrentonva.gov/Portals/0/PlanningZoning/Documents/Warr HD Guidelines with Graphics.pdf

SOLUTIONS TO EXTERIOR PAINT PROBLEMS ON HISTORIC WOODWORK & REPAINTING TECHNIQUES

This chapter is provided to discuss the reasons for exterior paint problems, offer solutions and demonstrate proper painting techniques. The best advice to lessen the hardship of a paint job is annual maintenance by attending to spot peeling through scraping, sanding, priming, if necessary, and recovering just that area in matching color versus waiting years for the rest of the building to need attention. If the color formula is unknown, take a chip to the paint shop for analysis.

The most time-consuming and most important work of a paint project is preparing the surface for new paint. All loose paint must be removed, the surface sanded, cleaned and bare spots primed to receive a new coating. Evaluate the overall condition of the wood elements and wall surface to discern where existing paint is peeling or showing signs of cracking, alligatoring, wrinkling, pulling away or bulging out from the surface and identify the causes.

PREPARATION PRIOR TO REPAINTING

1. Repair and maintain leaking or poorly functioning roof drainage, flashing, gutters and down spouts. Fasten an extender or ground leader to down spouts or install an underground French drainage system to carry water away from the foundation to deter rising moisture.
2. Remove all vegetation against the building. If foundation plants must remain, trim them three feet away from the wall. Remove overhanging tree limbs and never allow wisteria or other vines to grow onto the wall or elements. Plants attract moisture, mildew and paint failure.
3. Use the gentlest means possible to clean the surface. Sweep off dirt particles, cobwebs, bee and mud dauber nests. Hand wash with Trisodium Phosphate (TSP) with a sponge, soft bristle brush and garden hose from the eave downward and allow the wall to completely dry for several days. Do not spray from the ground or bottom upward which forces water behind boards.
4. Mildew occurs from dampness and fungi feeds on nutrients in the paint. Removing vegetation and trimming shrubs and trees off the building will increase air flow and allow more sunshine. Repairing poor drainage systems is a must. Existing mildew may be cleaned with a solution of a cup of non-ammoniated

- detergent, a quart of household bleach to one gallon of water, using a soft bristle brush. Additional bleach treatment may be necessary for dense mildew. Rinse thoroughly from the top down with a garden hose and allow several days of drying before applying any paint.
5. Remove peeling, cracking, wrinkling, blistering, alligatoring, etc., paint from wood surfaces with the gentlest means possible, using hand paint scrapers as much as possible. If electric hand sanders or electric scrapers are used, maintain an even plane with the wood so as not to gauge out or mar historic fabric. Rotary sanders may leave circular marks in the wood. A rectangular electric sander that vibrates horizontally is preferable. Use electric hot air guns or heat plates with caution.
 6. Never use destructive paint removal methods such as sandblasting, power blasting wet or dry gritty substances of any kind or power wash and do not use infrared paint peelers, propane or butane torches which all irreversibly damage historic woodwork. Power washing forces water into crevices, rips away the face of wood, as do sand or power blasting, and should never be performed from the ground up on any building.
 7. Chemical paint strippers are messy, may leave residue and generally present a threat to the environment. A peel-away chemical on paper stripper is available where the sheets are applied to the wall surface and left for hours, then pulled off. Several applications may be necessary, and the problem of environmental protections, the mess, residue and waste refuse to be disposed of discourages this method. Removing all of the residue is very tedious and if not properly done, the new coat will not adhere. The building will have to be washed down, again only with a garden hose from the eave down, and allowed to completely dry.
 8. Do not remove paint that is firmly adhering. Peeling and bare spots should be scraped, sanded, cleaned and primed with a light oil base or latex primer up to the edges of the firm paint and given a thin top color coat in latex to match the wall color. Remember thinner coats are best.
 9. After scraping to remove all loose paint, lightly sand all areas that have remaining paint to de-gloss, smooth fine hairline crazing cracks, feather out edges of thick layers and go over the bare spots. Sweep away dust and clean with a damp rag. Paint will not adhere long to dirt.
 10. When down to bare old wood, carefully sand and smooth weathering to a slightly brighter surface and carry the sanding over the outer paint edges. If long exposed, the wood has likely dried out and will need more treatment to accept a new paint film so it can soak into the wood. First, sweep away dust, wipe clean and then condition the wood with a fifty-to-fifty-percent mixture of boiled linseed oil and turpentine rubbed in and allow to dry for twenty-four hours. Turpentine alone sometimes is sufficient.

11. High quality wood putty may be used to repair deteriorated wood after cleaning out all loose particles and dust. If wood has rotted beyond repair, splice in matching timber sawn wood in kind to material, size, profile, texture, detail and technique. If an entire weatherboard or wood detail such as a bracket absolutely must be replaced, do so in kind to material, size, profile, texture, detail and technique.
12. NEVER caulk under weatherboard! Never seal up the building with caulk so it cannot naturally breathe and evaporate condensation through the walls! Caulk only vertical seams and vertical spaces along door and window frames or horizontal cracks in the boards, but do not caulk under the weatherboard. Even professionals make this mistake, but do not let them. Weatherboard is designed to overlap with the bottoms away from the walls purposely for breathing and for interior moisture evaporation. Sealing up the building with caulk will cause the paint to fail.
13. Remove all earlier caulking under weatherboard and the dust it brings out with it.
14. Do not wait too long to repaint after scraping, sanding and cleaning beyond the drying period or the edges of remaining paint may begin to peel.
15. Choosing the correct type of paint is important. Should the new coat be oil-base or latex? There is a good chance that both have been used on the building. The fewer and lighter the coats, the better for breathing, adherence and reduced failure of lower remaining films. Paint experts and analysts today advise that latex paint has greatly improved, and the earlier-used oil-based paints no longer have lead content so their effectiveness has decreased. Easier cleanup of latex is more appealing.
16. Stains are also another consideration and work well when down to bare wood, but they should be tinted, not natural, which is uncharacteristic on historic buildings. Stains can absorb into the wood better than thicker paint. Even if the building has remaining layers of paint, it is possible to have a stain colored to match. Examples and experimentation with good success of this technique are occurring at 71 and 74 Winchester Street where both owners are spot treating peeled down to bare wood areas of the weatherboard with tinted stain. These houses also demonstrate annual maintenance of peeling areas rather than full-scale paint jobs.

Here is the recommended paint application recipe for historic buildings, also underway at Colonial Williamsburg:

- Primer for bare wood spots - Oil-base primers will soak into the wood best. The newer solutions are lighter than earlier solvents and made to accept lightweight latex topcoats. Allow the primer to dry thoroughly according to the product directions.

- Use Latex paint as the topcoat - Latex is lighter and will better allow breathing between underlying layers. Try to apply only one coat over the primer and remaining paint layers. A change in color may need more than one coat of paint, if so, try not to exceed two because the more layers of paint, breathing and moisture evaporation is compromised increasing failure potential. It may be possible, after the first coat is thoroughly dry, to just brush over streaking areas rather than completely applying a second latex coat. Do use good quality paint.
- DO NOT APPLY THICK COATS. If the film is too thick, the outside will dry before the inside, causing chalking, blistering and peeling.
- DO NOT APPLY IN DIRECT HOT SUNLIGHT for the same reason as thickly-applied coats.
- DO NOT APPLY PAINT IN TEMPERATURES BELOW FIFTY DEGREES.
- DO NOT APPLY PAINT BEFORE EVAPORATION OF THE MORNING DEW OR LATER THAN 3:30 p.m. IN THE FALL AND 6:30 p.m. IN THE SUMMER.
- DO NOT APPLY PAINT IN THE RAIN OR WHEN THERE IS A THREAT OF RAIN. If it has rained, allow two or three days for the walls to dry before painting.
- ALWAYS CARRY A CLOTH TO WIPE AWAY ANY MISSED DIRT BEFORE APPLYING THAT PAINT BRUSH. Dirt will not allow the paint to adhere long. Also keep that paint scraper in a pocket. Do not take a chance that a stroke will make a missed peel stick.

ADDRESSING SPECIFIC PAINT PROBLEMS

Causes & Treatment for Peeling, Cracking & Blistering

1. Too many layers of paint: A sixteenth of an inch equals fifteen to thirty coats. The thicker the paint, the less flexibility and inability to withstand shrinkage. The wood cannot breathe, moisture cannot evaporate from the interior.

Treatment - When preparing for repainting, scrape the loose paint down to the wood, if possible, and sand to smooth the edges, wipe clean with turpentine, prime the bare spot with an oil-base primer and repaint only that area to match the color as closely as possible. Adding layers to adhering paint unnecessarily will only increase the chance of peeling. Repainting strictly for cosmetic reasons to change a color should not occur. A color change often means two or three more coats which contributes to the problem. Spot painting, therefore, is recommended.

2. Dirty wall surface or inadequately scraped loose undercoat when the last paint job occurred.

Treatment - Scrape off the loose paint, sand, clean and prime bare wood spots with oil-base primer and recover with matching topcoat color.

3. Peeling down to bare wood often means repeated moisture penetration caused by poor roof drainage including rusty gutters, failing hidden gutters, improper roof repairs, worn seams at the eaves and failed flashing.

Treatment - Repair and maintain the drainage system.

4. Painting over damp wood, in rain or too early in the morning or late in afternoon and in minus 50 degree temperatures.

5 Mildew from present moisture conditions can re-grow and push paint off. It can be an indicator of present moisture problems and should be carefully assessed.

Treatment - Determine the cause of the mildew and remove vegetation against the building. Clean away the mildew with a solution of a cup of non-ammoniated detergent and a quart of household bleach in a gallon of water. Allow to dry, scrape, sand and repaint as needed.

6. Insufficient priming. Priming is only necessary when the bare wood is revealed. Primer absorbs into the wood and allows the upper topcoat a binding medium.

Treatment - Scrape, sand, clean, allow to dry and treat the wood with the linseed oil and turpentine solution (half and half). Allow another twenty-four hours of drying, then correctly prime with an oil-base primer and repaint.

7. Incompatible paints cause inter coat peeling - over the years, varied practices by professionals and non-professionals leave a diversity of incompatible finishes. Latex over glossy oil-base paint will quickly peel, sometimes before the paint job is finished because it cannot adhere.

Treatment - Remove the layers down to bare wood by scraping and thoroughly sanding, clean the surface with turpentine, allow it to dry, prime with an oil-base primer and repaint.

8. Chalking or powdering by mild resin disintegration of paint surfacing is a slow aging and generally washes away with rainwater. However, excessive chalking of an upper color onto a different lower color or onto masonry surfaces is undesirable.

Treatment - Remove with a half cup of household detergent to a gallon of water using a soft bristle scrub brush. Following garden hose rinsing from above, dry thoroughly and repaint.

Causes of Alligatoring -

1. Water penetration into cracks causing crazing - fine hairline cracks. As moisture builds, then the sun bakes the area, alligatoring occurs. The good news is that bad alligatoring removes more easily than adhering cracking paint.

2. Cross-grain crazing = paint buildup.
3. When the alligatoring continues, the paint pops off in bits and bare wood dries out, absorbs moisture over and over.

Treatment – Scrape, sand and clean crazing with a damp cloth. Bare wood will have to be treated and possibly conditioned with the linseed oil and turpentine solution (half and half), primed with oil-base primer and repainted. Always allow full drying times.

Causes of Wrinkling & Bulging Paint -

1. Applying paint in the hot direct sunlight which dries the top glazing too quickly before the inner film against the wall, so shrinking and wrinkling of the new coat occurs.
2. Incompatible paints.
3. Caulking under weatherboard or over sealing with caulks.

Treatment - Never caulk under weatherboard. Remove with the dust it brings down. Scrape, sand both to remove paint and roughen that which still adheres, clean and start over.

APPENDIX F: ZONING MAP OF TOWN

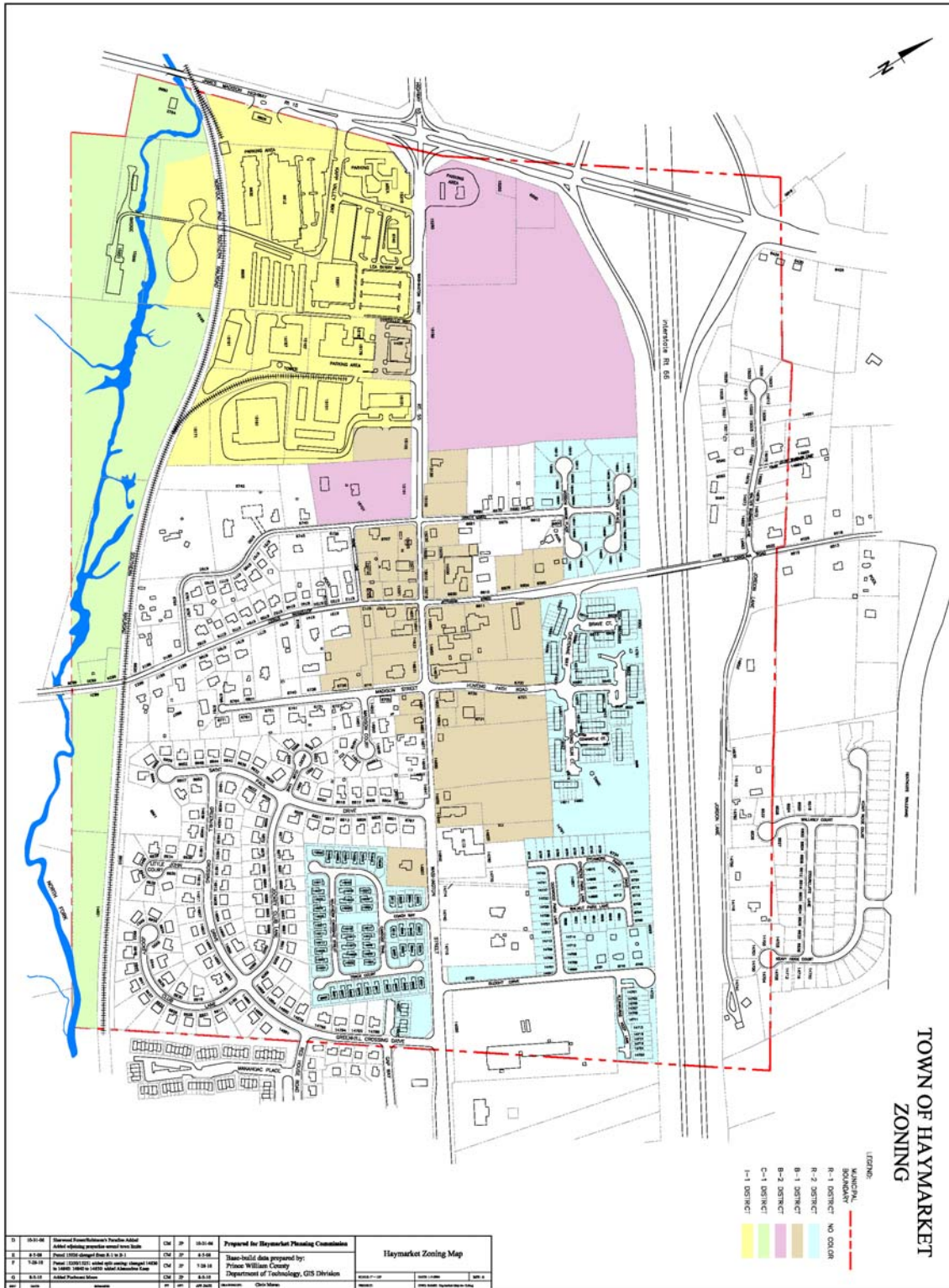

Attachment: arb_guidelines_adopted_by_council_09-2010 (6237 : ARB Guidelines Work Session)